

WATER UTILITY

CONSTRUCTION STANDARDS AND MINIMUM DESIGN CRITERIA FOR WINTER PARK RANCH WATER SANITATION DISTRICT

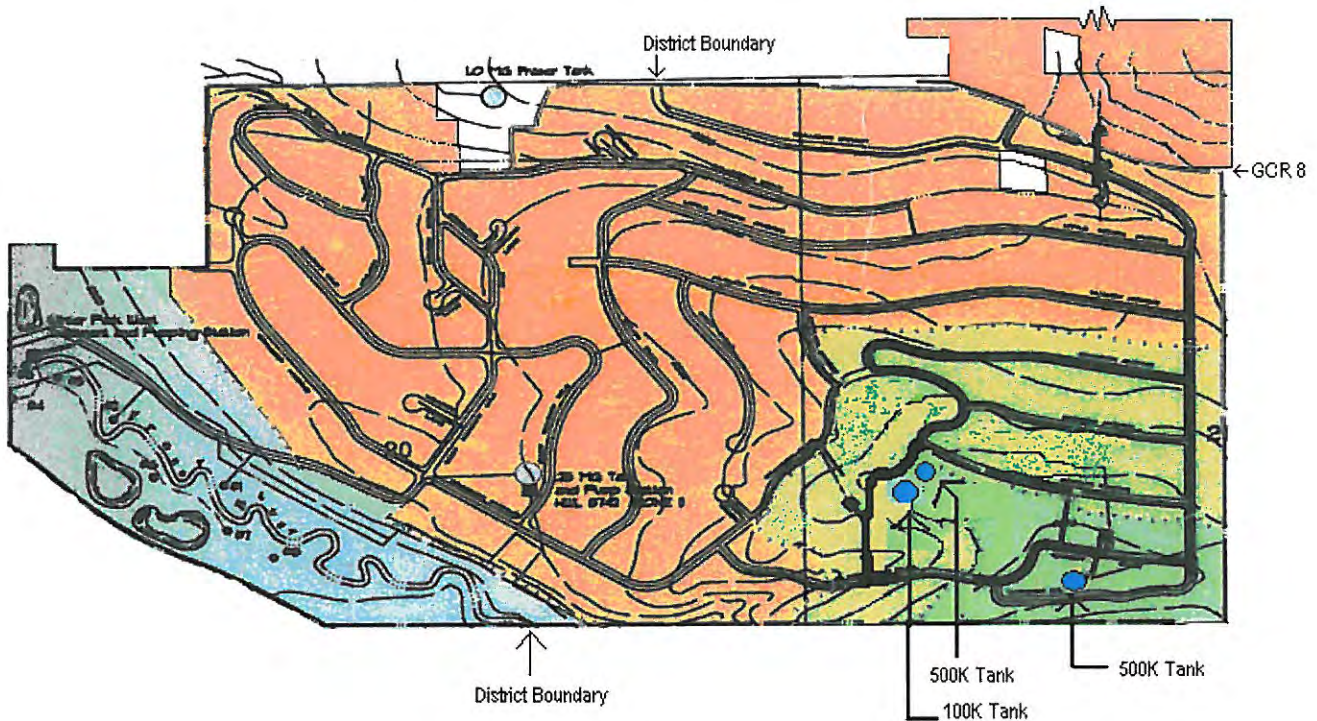

PREPARED BY:



Modified by Gary M. Cooper, P.E.

APRIL 2009

**WINTER PARK RANCH WATER & SANITATION DISTRICT:
WATER UTILITY CONSTRUCTION STANDARDS AND MINIMUM DESIGN CRITERIA**

**SECTION 1
GENERAL / EXPLANATORY MATERIAL**

1.1 APPLICABILITY

These technical standards are to be applied in conjunction with the other administrative and procedural requirements of the Winter Park Ranch Water & Sanitation District (District).

1.2 DEFINITIONS

Unless the context specifically indicates otherwise, the meaning of terms used herein shall be as follows:

Actual Cost shall mean all direct costs applicable to the construction of a given facility, including surveys, preliminary and design engineering, construction, inspection, administrative, regulatory agency fees, bond fees, all required easements and/or rights-of-way, plan approval fees, "as-built" drawings, attorneys' fees, and other costs necessary for completion.

Applicant shall mean any person requesting to receive a Permit to connect to the District's water system or to receive water service from the District.

Board and Board of Directors shall mean the governing body of the Winter Park Ranch Water & Sanitation District.

Contractor shall mean the entity working on behalf of the developer to construct utilities or other physical improvements.

Customer shall mean any person, company, corporation, governmental authority or agency authorized to use the public water, irrigation, sewer or drainage systems under a permit issued or otherwise authorized by the Board of Directors or the District Manager.

Developer shall mean the person(s), firm, joint venture, partnership or corporation which is the owner or operator of land and which seeks to have the land served by the District.

District shall mean the Winter Park Ranch Water & Sanitation District or the Board of Directors of the District.

Engineer shall mean the engineering firm, or duly authorized representative, designated by the District to act on its behalf in all engineering and related matters. This item includes an Inspector employed by the Engineer.

EQR is an abbreviation for Equivalent Residential Unit which is an average single-family detached residence or the equivalent, from a systems demand standpoint.

Inspector shall mean the Manager, Superintendent, Engineer, agent, officers, employees of the District or other person so designated by the Manager to perform inspections pursuant to District Rules and Regulations and these Construction Standards.

Local Facilities are those facilities generally designed primarily to serve individual subdivisions or plats. Examples are: water distribution systems and collector sewer lines.

Manager shall mean Manager of the District, or, the Manager's duly authorized agent.

Owner shall mean the land's record title holder or lessee with planning powers.

Oversize Costs this item is applicable to part of the costs of a water distribution line to be installed within, or for, a subdivision; but which the District has also assigned a transmission function which results in the need for a larger pipeline. Oversize costs are the difference between the actual costs of the size line required by the District and the size required by the Developer; however, for purposes of determining oversize, the minimum size shall be assumed to be 8-inch diameter for water. Engineering and inspection costs are assumed to be proportional to estimated or experienced construction costs. Incremental costs will be allowed for line fittings, valves, manholes and other appurtenances (if a size increase is required).

Permit shall mean written permission of the Board of Directors authorizing connection to a water main of the District granting Applicant a license to use the water system or to receive water service from the system owned, operated or served by the District.

Person shall mean any individual, firm, company, association, society, corporation or group.

Preliminary Acceptance shall mean formal notification by the District to the Applicant that all the requirements of section 2.8 "Checklist" have been met.

Regional Facilities shall mean those facilities generally serving the District's service areas as a whole. Examples are: water sources, water treatment plants and tanks, and water transmission lines.

Shall is mandatory; "May" is permissive.

Water Main shall mean a District -owned water pipeline, carrying potable water only and shall be installed in a public street or easement.

Water Service Line shall mean the privately-owned water line extending from the water main to the Customer's building, and shall include the tap on the main, corporation stop, curb valve and PRV valve.

SECTION 2

LOCAL DISTRIBUTION SYSTEM STANDARDS

2.1 GENERAL

Local water facilities are considered to be engineered improvements which are designed for specific applications. All designs, drawings and specifications must be prepared by, or under the direction of a Professional Engineer registered in Colorado, whose seal must be on a record set of documents. Local collection systems are the responsibility of the Developer, who is responsible for the design and construction and the costs thereof and for payment of actual cost of design reviews and other reviews and inspections provided by the District.

The standard details and specifications contained herein are minimum design standards which the District will accept in order to facilitate perpetual operation and maintenance procedures. In addition, the Applicant's Engineer must also design in accordance with the minimum standards of other applicable regulatory agencies. Review and approval of local facilities designs by the District, its Engineer, or other agencies (including but not limited to East Grand County Fire Protection District # 4) shall not relieve the Engineer of Record from responsibility for adequate design. After service line/main is changed, use of District's personnel during the construction phase will be charged to the owner/developer.

Contractors working for the District must perform all work between 7:30 a.m. and 5:00 p.m., Monday through Friday. No work will be allowed after these hours or on Saturday, Sunday or Holidays without advance approval from the District. Work performed outside of regular week day hours will require a District Inspector to be on-site to oversee the project. The Inspector's time will be charged to the contractor at a rate of time and one half of the inspectors total compensation.

No contractor shall tap a District water or sewer line outside of Monday through Thursday. A District Inspector must be present to approve all taps and service line before any trench is back-filled. If a tap or service line is back-filled without being inspected by the District, it must be dug up and exposed so that the District Inspector can approve it.

All construction work shall be performed between May 15 and October 15, or as allowed by the Grand County Road and Bridge Department and the District.

2.2 APPLICABILITY

The District will not recommend the issuance of a building permit for a development until the Design Documents are approved. This section of the Water Utility Construction Standards and Minimum Design Criteria defines the process and minimum requirements for preparing and submitting the Design Documents.

2.3 DRAWINGS

Unless otherwise approved by the District, all design drawings shall be on 24" x 36" mylar, using ink for all background information and permanent pipeline work. Drawing scale for area plans shall be 1" = 50'. Original mylars shall be delivered to the District after acceptance of the final design.

Prior to the construction or installation of any Local Facilities, the Developer shall submit Design Documents to the District for review and approval. [The Developer is encouraged to submit preliminary designs for review of the overall layout, prior to producing this set of design drawings for review.] Each review package submitted to the District shall consist of four (4) blue line drawings, and a cover letter describing the project. One copy is for the District, and three copies are for review by the District Water Utility Engineer. The Developer must also make an independent submittal to the Fire Protection District, which has its own requirements for submitting review packages. The District and/or its Engineer may request additional documentation or calculations, depending on the complexity of the application.

The cover sheet of each design drawing set shall have an "approval block" affixed thereto which provides for the signatures of authorized representatives of the District, the District's Engineer, and the Fire Protection District. The "approval block" shall be a facsimile of that appended to these Standard Specifications, "Standard Approval Block," Drawing 2.1. Blue line drawings submitted for approval must be stamped and signed by a Professional Engineer registered in Colorado.

Construction may not begin until the Design Documents have been approved by the District. The construction contractor(s) must have a copy of the signed, approved design documents in their possession at the construction site.

After completion of construction, the Developer shall also provide a complete set of record drawings for the facilities. The record drawings shall show sufficient dimensioned ties to reasonably permanent surface features for all buried facilities to allow for future locating. The record drawings shall be mylar transparencies suitable for blue line reproductions. As-builts shall be in general conformity to the Standard Drawing "Typical As-Recorded Drawing Information," Drawing 2.2. Two blue line copies and one mylar copy of the record drawings, stamped and signed by the Developer's P.E. must also be submitted for the District's records. The Developer shall also submit an electronic media copy to the District in AutoCAD format using control points provided by the District.

2.4 REQUIRED EASEMENTS

Where Local Facilities are to be located out of the public right-of-way, the Developer shall be responsible for obtaining easements required for the construction, maintenance, and operation of the facilities. The legal description for the easements shall be prepared by a Registered Land Surveyor in the State of Colorado. Easements shall be in a form acceptable to the District and shall be shown on the design drawings. **The District will not approve the Design Documents until all required easements have been deeded to the District.**

In general, the minimum width of easements for a single pipeline shall be 30 feet. Temporary construction easements shall have a minimum width of 40 feet. Wider easements may be required for deep sections of pipeline, multiple lines, steep terrain, or where otherwise required by the District. In general, the easement to contain both a water line and a sewer line shall be no less than 50 feet.

2.5 POTABLE WATER DISTRIBUTION SYSTEMS

2.5.1 Design/Sizing. Water mains shall be designed to meet the most stringent of the following two conditions:

- a. Maximum hourly demand with pressures not less than 40 psi at any point of the distribution system, or
- b. Maximum daily demand rate plus fire flow demand (as determined by ISO guidelines) with delivery pressures of not less than 20 psi at the hydrant.

The normal minimum size water distribution main shall be 8" or 6" for short looped lines in single-family residential areas. Six-inch mains may be individually approved by the District for dead-end mains serving no more than 15 residences with a fire hydrant near the end of the line, if this location and delivery rate meet the requirements of the Fire Protection District

Water main sizing and connections shall be reviewed with the District's Water System Engineer prior to final detailing and drafting. Stainless Steel "wet" taps are generally preferable to maintain service to the District's constituents. The systems shall be designed to maximize interconnections and strengthening of the District's water system. Where certain lines may also have a transmission function, in the opinion of the District, the District may direct that such lines be oversized, and the Developer's Engineer shall so design the system. In this case, the District must pay the incremental oversize costs.

Regulations normally require a 10-foot (O.D. to O.D.) minimum horizontal separation between water, sewer and irrigation water mains. When located in public streets, potable water pipelines shall normally be located about 11 feet north or east of, and parallel to, the roadway centerline. Curved water line alignments are to be avoided if the water line is laid in the same easement or roadway as a sewer line. To facilitate future field location of water lines, they are to be offset a minimum of 10' from sewer lines, using fittings to make direction changes parallel to sewer line.

Whenever a crossing must occur where an irrigation water or sewer main passes within ten feet horizontally of water main, and where the water main is not at least 18-inches vertically clear above the irrigation water or sewer main, special construction will be required in accordance with "Sewer Crossing Water Line Detail," Drawing 2.3, and "Pipe Encasement Detail - Sewer," Drawing 2.4. Adaptor couplings used in joining sections of sewer, per Drawing 2.3 are to be similar and equal to Smith-Blair Style 411 steel pipe Couplings. The couplings sleeves & followers are to be steel with interior and exterior

epoxy coatings. Coupling bolts shall be high strength, low alloy steel meeting the requirements of ASTM A325, Type 3. These coupling assemblies are subject to the same requirements for polyethylene sheathing as specified for ductile-iron pipelines.

2.5.2 Pipe, Fittings. All water mains shall be ductile-iron pipe, conforming to ANSI A21.51, Class 52 minimum thickness. Polyvinylchloride (PVC) shall be allowed were a soils engineer has determined the soils to be corrosive (hot soils). All PVC pipe shall be manufactured in accordance with AWWA C900 specification. PVC water main shall be Class 200 Dimension Ratio 14 (minimum pressure class200) Pipe joints shall be push-on type in accordance with ANSI A21.11. Pipe shall have a cement mortar lining meeting AWWA 104 and bituminous exterior coating.

Fittings shall be ductile-iron or cast-iron, minimum 250 psi minimum working pressure, conforming to AWWA C153 or C110 with mechanical joint connections meeting AWWA C111. Lining and coating shall match pipe. PVC pipe joints shall be push on joints using integral bell joints with an elastomeric gasket in accordance with ANSI A21.11. Electrical conductivity (Pre-welded tabs or other pre-approved means) shall be maintained throughout the entire distribution system, to facilitate later location of buried pipelines. Tabs must be corrosion-free, primed and painted at the factory prior to delivery to the site. Electric conductivity for PVC pipe shall be maintained by using a 4 gauge copper wire installed on top of all C900 pipe and brought to the surface in the valve boxes.

Sheathing: All ductile-iron pipelines, valves, and fittings shall be polyethylene sheathed in accordance with ANSI A21.5, AWWA C105, 8 mil minimum thickness. Installation shall comply with Drawing 2.5, "Polyethylene Wrap Details." In certain circumstances and with technical documentation, the District may waive sheathing requirements.

Line Valves: Line valves shall be provided to allow isolation of parts of the system for maintenance or repair. They are required approximately every 600 feet, or more frequently at intersections of mains to allow isolation of loops and branches. A line valve is required between fire hydrants. Line valves shall comply with requirements for "Buried Valves."

Buried Valves: Valves, 12" and smaller, shall be non-rising stem, resilient seat bronze mounted gate valves with mechanical joint ends conforming with AWWA C500. Valves shall have 2" square operating nuts and open left (counterclockwise rotation). Valves shall be Mueller, Clow, Waterous, or approved equal.

Valve Boxes: Each buried valve shall be provided with a cast-iron valve box and round cover. The box shall have a minimum inside diameter of 5 1/4" and be adjustable in length and of the screw type. The word "WATER" shall be cast on the cover. Valve boxes shall be "wide oval base" by Tyler, Clow, or approved equal. Valve boxes shall

allow for at least 3" additional extension above the level required for final grade at the time of installation. The top of all valve stems (including extensions) shall be located between 36" and 48" below final grade.

Fire Hydrants: Fire hydrants shall be **Mountain specified hydrants** of the dry barrel type and conform to AWWA C502. Hydrants shall have a 5 1/4" main valve, two 2-1/2" hose connections and one 4 1/2" pumper connections. Height of connections shall comply with Drawing 2.11. Hydrants shall have 6-inch mechanical joint connections and safety traffic flange. Fire hydrants shall be Mueller Centurion No. A-423, Waterous Pacer WB-67 with bronze seat ring, or approved equal.

Blow offs: Blow offs shall comply with Drawing 2.6, "Blow-Off Installation for 12" and Smaller Pipe." The top of all blowoff valve stems (including extensions) shall be located between 36" and 48" below final grade.

Air-Release Valves: Shall be provided at high points in the water distribution system. This may take the form of a fire hydrant or 2" blowoff (both manually operated), or an automatic air-release-vacuum valve. The proposed location and means must be pre-approved by the District.

2.5.3 Pipeline Installation. Water pipelines shall be installed in a thorough and workmanlike manner in accordance with the Design Documents that have been approved by the District. Work around existing water service lines shall require all due care to not disturb the existing service. The minimum bedding and backfill requirements for pipelines and appurtenances shall be as shown on Drawing 2.7 "Water Main and Service Bedding and Backfill Details." The minimum cover shall be 9 feet from top of water line to finished grade. Pipelines shall not be placed deeper than 11 feet without prior approval by the District.

A minimum of 7 feet of cover will be allowed if at least 2 inches per foot under 9 feet of an approved pipeline insulation is provided, per Drawing 2.7. If insulation is installed, use approximately 6" of sand or squeegee for the pipe zone materials above and beneath the insulation to protect it from breakage during backfill.

If the bottom of the excavation is soft or unstable, and in the opinion of the District, is not a satisfactory support for the pipeline, further depth and/or width shall be excavated and refilled to 6" below the pipe outside diameter (excluding bells) with Trench Stabilization Material, as specified in Pipe Bedding and Backfill.

All pipeline fittings (i.e., bends, tees, plugs, and caps) shall be installed with mega-lugs and concrete thrust blocks adequately designed for the specific application. Thrust blocks shall be cast-in-place with concrete having a minimum compressive strength of 3,000 psi. Minimum requirements for thrust blocks are as shown on Drawing 2.8 "Concrete Thrust Blocks."

Alternate means of thrust restraint may be considered and approved for use where proved to provide similar restraint. Supplemental restraint may also be required where the Engineer believes the soil bearing pressures to be inadequate, or where the Engineer is concerned about subsequent movement due to slope or other conditions of service. See Drawing 2.9, "Mechanical Joint Restraint Details", and Drawing 2.10, "Length of Restrained Pipe". Valves near a fitting must be tied back to that fitting, using rodding, mechanical joints, or mega-lugs.

2.5.4 Pipe Bedding, Definitions and Backfill (a thru e)

a. Trench Zones. The terms "Bedding Zone", "Pipe Zone" and "Backfill Zone" shall refer to the trench zones identified in the Standard Details, Water Main Bedding and Backfill Detail.

- (1) Bedding zone. The Bedding Zone shall consist of all material placed below the pipe invert or, when permitted, the native materials graded and prepared for direct placement of the pipe.
- (2) Pipe zone. The Pipe Zone shall consist of all material placed above the pipe invert to an elevation shown on the details.
- (3) Backfill zone. The Backfill Zone shall consist of all material above the Pipe Zone.

- b. Material. All bedding and backfill material shall have the approval of the Engineer. All bedding and backfill material shall be free of frozen material, organic material and debris. The materials to be used in each trench zone are indicated on the Standard Details and these materials are described below. All materials may be subject to gradation tests and compaction tests prior to approval of the use of that material. The test results shall be submitted to the Engineer for approval and verified as to their accuracy. These tests shall be performed at no cost to the District or its agents.
- (1) Sand bedding or sand backfill material. This material shall be a clean, well-graded sand and shall conform to the following limits when tested by means of laboratory sieves:

Well-Graded Sand

Sieve Size	Total Percent Passing by Weight
3/8-inch	100
No. 4	70 - 100
No. 8	36 - 93
No. 16	20 - 80
No. 30	8 - 65
No. 50	2 - 30
No. 100	1 - 10
No. 200	0 - 3

- (2) Road base bedding material or road base backfill. This material shall be Class 6 aggregate base course as specified by the State of Colorado Department of Highways; and shall meet the following gradation:

Sieve Size	Total Percent Passing by Weight
3/4-inch	100
No. 4	30 - 65
No. 8	20 - 55
No. 200	3 - 12

- (3) Squeegee Sand. This material shall be clean, well graded and conform to the following limits when tested by means of laboratory sieves:

Sieve Size	Total Percent Passing by Weight
3/8-inch	100
No. 4	20-80
No. 8	10-25
No. 16	0-10
No. 200	0-2

With this material, depending on the nature of the surrounding soils and ground water conditions, the District may require a geotextile envelope around the backfill zone and/or the installation of clay dams in the trench. Clay dams, if required, will typically be placed at about one per 400 feet of sewer.

- (4) Granular bedding or granular backfill material. This material shall be imported crushed rock or angular surfaced gravel and meet the following gradation (ASTM D448, No. 67):

Sieve Size	Total Percent Passing by Weight
1-inch	100
3/4-inch	90-100
3/8-inch	20-55
No. 4	0-10
No. 8	0-5

With this material, depending on the nature of the surrounding soils and ground water conditions, the District may require a geotextile envelope around the backfill zone and/or the installation of clay dams in the trench. Clay dams, if required, will typically be placed at about one per 400 feet of water main.

(5)	“7/8-inch Aggregate”:	Total Percent
	Sieve Size	Passing by Weight
	12-inch	100
	1-inch	90-100
	3/4-inch	60-80
	3/8-inch	0-15
	No. 4	0-5

With this material, depending on the nature of the surrounding soils and ground water conditions, the District may require a geotextile envelope around the backfill zone and/or the installation of clay dams in the trench. Clay dams, if required, will typically be placed at about one per 400 feet of water main.

- (6) Select material. Select material shall not be permitted unless authorized by the Engineer. This material shall consist of suitable material screened from the excavated earth having no rocks or stones greater in size than 2 inches for DIP or RCP (reinforced concrete pipe) and 3/4-inch for all other pipe.
- (7) Trench stabilization material. This material shall be a 3/4 to 12-inch uniformly-graded, crushed rock or concrete aggregate.
- (8) Backfill material. Backfill material shall consist of suitable material from the excavated earth, meeting all the requirements of the Specifications.

No boulders over 6 inches in any dimension shall be allowed in the top 12 inches of the trench. All boulders shall be carefully placed so that no damage will be done to the pipeline. No backfill material shall have boulders larger than 24 inches in any dimension. Boulders larger than 8 inches in any dimension shall be carefully lowered into the trench until the backfill is 4 feet over the top of the pipe.

c. Bedding and Backfill Installation:

- (1) General. Unless accurate results cannot be obtained, the compaction requirements shall conform to maximum dry density according to ASTM D698, Moisture-Density Relations of Soils (Standard Proctor). When the ASTM D698 test is not applicable, the percentage compaction requirements shall conform to ASTM D2049, Test for Relative Density of Cohesionless Soils.

The Developer is responsible for providing (at no cost to the District) adequate materials testing and/or geotechnical engineering resources to provide proper Quality Control and response to Quality Assurance directives by the District or its agents.

When required by the Engineer, the Developer shall excavate backfilled trenches for the purpose of performing compaction tests at locations and depths required by the Engineer. The Developer shall be responsible for reinstalling and compacting the test excavations at no additional cost to the District.

- (2) Bedding zone installation. Bedding material shall consist of the material on which the pipe is placed in accordance with the Pipe Trench Details. Bedding material shall be placed to the required elevation of the pipe invert. Tamping equipment shall be used to thoroughly tamp the bedding material to a minimum of 95 percent maximum dry density (Standard Proctor) or to 75 percent relative density. The moisture content of the material shall be within 2 percent of optimum.
- (3) Pipe zone installation. After bedding material has been placed and approved and after the pipe has been installed and approved, the pipe zone backfill shall be installed to an elevation shown on the details on the drawings.

The backfill material shall be as specified on the details and shall be placed and compacted in distinct, separate lifts not to exceed 6 inches of loose depth; except that the first loose lift shall not be higher than the pipe centerline (springline). If select backfill materials are permitted in this zone but acceptable select backfill material (suitable for placement within 12 inches of the pipe barrel) is not available at any particular location, the Developer shall use imported granular backfill material. Compaction shall meet the requirements of "Bedding Zone Installation," utilizing T-bars or mechanical tamping equipment.

- (4) Backfill zone installation. Unless otherwise provided in the Special Construction Provisions, the following method of installation shall apply. After the pipe zone backfill has been placed and approved, the trench shall be backfilled. All backfill above the pipe zone backfill shall be carefully placed in the trench in lifts no greater than 2 feet. Each lift shall

be compacted by mechanical equipment to 90 percent of maximum laboratory dry density (Standard Proctor). After the trench is backfilled to the ground surface a loaded dump truck or loader placed in the trench line shall compact the backfill by its wheel load. No less than two passes shall be made. If the backfill is depressed below the finished grade elevation, the depressed area shall be refilled and compacted. The backfill shall be mounded higher than the adjacent ground to allow for settlement.

- (5) Backfill zone installation in roads and streets. Beneath all traveled ways in roads and streets, highway shoulders and within 15 feet of pavement in State Highway Department rights-of-way (unless otherwise specified on the plans) backfill shall be carefully placed and compacted up to the limit of base course material or to gravel. Compaction shall be by mechanical tamping in 8-inch maximum loose lifts using mechanical or hand tampers, weighing not less than 20 pounds, or vibratory rollers. Flow fill shall be used in all trenches in paved roads where the pavement is less than 5 years old. Comparable products can be used with District approval. All other means must be approved in writing by the District. All backfill shall be compacted to 95% of maximum laboratory dry density (Standard Proctor) or 70 percent relative density. The material shall be within 2.0 percent of optimum moisture content.

The Developer may request approval of alternate means of compaction. Such request must be submitted to the District in writing. Approval of the compaction method will be made by the District only in writing. Use of specified or approved compaction methods does not relieve the Developer from providing a completed project meeting the intent of this Specification.

- d. Maintenance of Backfill. All backfill shall be maintained in a satisfactory condition and all places showing signs of settlement shall be filled and maintained for a period of two years following the date of final acceptance of all work performed. When the Developer discovers or is notified by the Engineer or the District that any backfill is not in compliance with these requirements, the Developer shall correct such condition at once. Any utilities and road surfacing damaged by such settlement shall be repaired by the Developer to the satisfaction of the District and Engineer. In addition, the Developer shall be responsible for the cost to the District of all claims for damages filed with the Court and actions brought against

the said District for, and on account of, such damage.

- e. Erosion control. Erosion Control is the responsibility of the contractor and shall conform to guidelines as recommended by the Grand County Department of Planning and Zoning. Re-vegetation is required upon completion of all projects in the District.

2.5.5 Fire Hydrant Installation. Fire hydrants shall be located as required by the District and the Fire Protection District. The Developer shall be required to obtain the approval by the Fire Protection District for fire hydrant locations, and to provide documentation of that approval to District. Fire hydrants shall be installed in accordance with the drawing "Standard Fire Hydrant Detail," Drawing 2.11.

2.5.6 Testing. All finished water lines, after reaction blocking is in place, shall be pressure and leakage tested at not less than 150 psi for a two-hour period. If working pressure is greater than 100 psi, the test shall be performed at 1.5 times the expected working pressure. Unless approved by the Engineer no lines longer than 1200' shall be tested at one time.

No pipeline installation will be acceptable until the leakage is less than the amount computed by the following formula:

$$L = \frac{SD(P)^{0.5}}{133,200}$$

Where:

- L = Allowable leakage in gallons (per hour)
- S = Tested length of pipe (feet)
- D = Nominal diameter of pipe, inches
- P = Average test pressure during the test, psi

2.5.7 Disinfection. All water piping shall be disinfected in accordance with AWWA C601 after all construction work has been completed. Chlorine shall be added to the water at the necessary locations in the amount to form a 50 ppm free chlorine residual. The chlorine solution shall be left in the pipelines for not less than 24 hours, during which time all valves(except isolation valves) and fire hydrants shall be operated in order to disinfect the appurtenances. Extreme caution shall be taken to insure that the "highly" chlorinated water does not contaminate any potable water. After that length of time, the chlorine residual of the solution, at any place in the system, shall not be less than 10 ppm. All chlorination work must be done in the presence of the Engineer. At the end of 24 hours, the line is to be flushed and a bacteriological test is to be performed by a "state" certified laboratory to insure adequate disinfection, at the cost of the Developer. Special provisions (at no additional cost to the District) must be made to assure any highly chlorinated water is not discharged to the ground. The Developer must submit the "method of disposal" for this chlorinated water prior to any testing.

2.5.8 Electrical Continuity. The Developer must demonstrate, to the satisfaction of the District, that all water mains constructed have electrical connectivity between valves, hydrants and appurtenances.

2.8 CHECKLIST

Checklist for Preliminary Acceptance of District Facilities. To be completed after construction and prior to any service connections.

- 2.81 Construction of all District facilities completed to District Standards and to the approved plans.
- 2.82 All facilities tested to District Standards and accepted by the District (Furnish copies of soils and material tests)
- 2.83 Permanent survey monuments set at the corners of all easements.
- 2.84 Record drawings meeting District Standards and sealed by a registered Professional Engineer, in the form of blue-line drawings (set of three (3)), one mylar transparency, and three (3) DVD's shall have been submitted to the District. All survey control shall use the geodetic values for control established for the District's G.P.S. mapping.
- 2.85 Furnish a summary of total construction costs (including design costs) of all applicable sewer drainage facilities (include only facilities to be deeded to the District).
- 2.86 Warranty Deed for all facilities to be owned by the District.
- 2.87 Two year Maintenance Bond to begin after the date of preliminary acceptance, except that if deficiencies are identified and repaired, a new two-year maintenance bond for the repaired Work is to begin starting on the date of preliminary acceptance of the repaired Work.
- 2.88 Payment of all fees and confirmation from District's Attorney that the applicant for dedication of the facilities is not in default under any

agreements with the District and/or Grand County and/or any appropriate municipality.

- 2.89 The District shall be provided any and all easements necessary to maintain the infrastructure being accepted by the District.
- 2.90 All punch list items arising during the two (2) year warranty shall be completed.
- 2.91 The District will not turn water on for any structure until the permanent heating system is functional.
- 2.92 The District may exercise every valve and curb stop prior to final acceptance.

SECTION 3 SERVICE LINE STANDARDS

3.1 GENERAL

No service line may be constructed without prior approval from the District. The Applicant must provide adequate information describing the nature of the building or development to be connected, the proposed service line size, and the proposed connection point of the service line to the main. A site plan, showing the location of the proposed service line relative to other utilities on and adjacent to the property must be presented. The drawing must show the location of buildings served and parts of the site that are to be paved or otherwise intended to be kept clear of snow, and must also show depth of cover over the service line.

District personnel will return one time to locate the curb stop and turn on service during the construction period. Additional return trips will be charged to the owner.

The sizing of water service lines shall be the responsibility of the Applicant. When requested by the District, the Applicant shall, at his expense, furnish data, plans, calculations, or other information as required for the evaluation of the service size. Service lines are the responsibility of the Developer, who is responsible for design and construction and the costs thereof and for payment of actual costs of review and inspection provided by the District.

Ownership: The service line, from the main (including the corporation stop) to the point of connection to the building(s) is the property of the owner of the lot served. Repairs are the responsibility of the property owner, who is responsible for obtaining the necessary permits for the work.

All water service lines are to be constructed in accordance with applicable codes, generally accepted good construction practices, and the minimum standards and criteria contained in this document. The details are provided for standardization purposes only, and represent minimum design standards which may require upgrading for specific applications.

No service line shall be connected to a main which has not been pressure tested, disinfected and accepted by the District.

3.2 POTABLE WATER SERVICES

3.2.1 Sizing. Sizing for potable water services shall be made in general conformance with AWWA Manual M22, "Sizing Water Service Lines and Meters." When requested by the District, the Applicant shall, at his expense, furnish data, plans, calculations, or other information as required for the evaluation of the service size.

3.2.2 Service Connections. No connection between the water system of the District and the water facilities of the Owner may be made except in a public street adequate to

accommodate this connection or in a similar place to which the District has as free a right of access as it would have in a public street, and which otherwise is suitable for buried pipe.

Where parallel or approximately parallel to a structural wall, the service shall be at least 5' from the wall. Penetrations through structures shall be approximately at right angles and shall provide flexibility such that the service will not be damaged by settlement of the structures.

Water and sewer service lines shall have 10' minimum of horizontal separation. Where this separation is impractical, the District may permit other separation requirements, in accordance with applicable standards. If a water service line passes under a sewer main, the sewer is to be encased per Drawing 2.4 or modified to have "no bell" construction per Drawing 2.3 and constructed of PVC pressure pipe.

The minimum cover shall be 9 feet from top of water service line to finished grade. A minimum of 7 feet of cover will be allowed, if at least 2 inches for each foot under 9 feet of an approved pipeline insulation is provided (maximum of 4"). The insulation installation is to be per Drawing 2.7. If the service line passes beneath a paved area outside the roadway, the line is to be insulated per Drawing 2.7.

The water service shall be laid at uniform grade and in straight alignment. A reference mark shall be placed on the curb above the service line.

3.2.3 Cross Connections/Backflow. Cross connections of any type that permit a backflow condition from any source other than the District 's potable water mains are prohibited. The District will not provide water service to any customer unless the potable water supply is protected from potential or actual cross connections as required by State and District regulations.

A. Multifamily Buildings:

1. Shall be defined as one service line into a building that contains two or more units(s.f.e.).
2. An approved Reduced Pressure Principal Backflow Assembly (RPZ) is required.
3. Each Backflow Prevention Device (bfp) device shall be located as close to the incoming service line, upstream of any other uses, (except a pressure reducing valve (prv)) and accessible.
4. The bfp device must be protected from freezing.
5. It is illegal to tamper with, by-pass, or remove any bfp device that has been installed.

6. All bfp devices must be tested by a certified bfp tester on an approved schedule. Test results shall be sent to the District, as required by law, but at least annually.
7. All outside hose bibs shall be equipped with backflow prevention.

B. Single Family Standards:

1. Defined as one service line into each individual unit (sfe).
2. An approved double check is required for all single family dwellings constructed after January 1, 2009.
3. An approved RPZ is required if the degree of hazard is determined to be higher than degree of hazard for the double check.
4. Each bfp device shall be located as close to the incoming service line, upstream of any other uses,(except a prv) and it must be accessible.
5. The bfp device must be protected from freezing.
6. It is illegal to tamper with, by-pass, or remove any bfp device that has been installed.
7. All bfp devices must be tested by a certified bfp tester on an approved schedule. Test results shall be sent to the District, as required by law.
8. All outside hose bibs shall be equipped with backflow prevention.

3.2.4 Pressure Regulation. All services shall be equipped with a pressure reducing valve (PRV), except where specifically exempted by the District. The PRV shall be upstream of all uses. The PRV shall be set for a downstream pressure not exceeding 70 psig.

3.2.5 Water Service Materials.

Insulated four gauge thaw cables are required, with brass clamps to the corp. stop, the curb stop and the water line inside the residence. Cables are to be run up the curb stop valve key pipe for access. Contact your plumber for specific details.

Water Service Pipeline: The water service pipeline shall be Type K, soft copper conforming to ASTM B88, unless otherwise specifically approved by the District. Fittings shall be brass or copper alloy. Connections shall be by compression type fittings and no soldered joints or flared ends shall be permitted underground.

Corporation Stops: Corporation stops shall be used for the connection of services (2-inch and smaller) to the water main. Corporation stops shall be brass and conform with AWWA C800. The inlet shall be standard AWWA corporation stop inlet thread and the outlet shall be for compression type "K", 1" or less, copper service pipe. Corporation stops shall be Mueller H-15000, Ford F-600, or approved equal, provided with an insulating coupling for potable service.

Curb Stops: Curb stops (sometimes called "stop boxes") shall be placed per Drawing 3.1 for all services 2" and smaller. Curb stops shall be brass and conform with AWWA C800. Connections shall be for compression type "K" copper service pipe. Curb stops shall be Mueller H-15204, Ford B-22, or approved equal.

Service Saddles: Service saddles shall be used for all water taps on any pipe other than DIP (Ductile Iron Pipe). For DIP, ¾" taps may be made without using a service saddle on 6" pipe; ¾" and 1" size taps may be made without service saddles on pipe 8" size or larger. All other DIP taps shall be made with a double strap bronze saddle, Smith Blair No. 357, Rockwell No. 323 or approved equal.

3.2.6 Meters. Meters are not required at this time, however owners are strongly encouraged to install meter yokes with appropriate valving, to simplify meter installation at some date in the future when the District will require meters.

3.3 CONSTRUCTION

3.3.1 General. The service line connection shall be constructed as shown in Drawing 3.1, "Service Line, Stop Box and Inside Meter Installation."

All excavations for water service installations shall be adequately guarded with barricades and lights so as to protect all workers including the public from hazards per existing Governmental requirements including but not limited to OSHA requirements. Utilities, streets, sidewalks, parkways, and other public or private property disturbed in the course of work shall be restored to their original condition in a manner satisfactory to the District or other affected owners or jurisdictions.

3.3.2 Service Line Excavation, Bedding and Backfill. All excavations required for the installations of a water service shall be open-trench work, unless otherwise approved by the District. The services shall be bedded and backfilled in accordance with the minimum cover and/or insulation requirements of Section 3.2.2 and "Water Main / Service Bedding and Backfill Detail," Drawing 2.7. The bedding and pipe zone material within 12" of the water service line shall be select native soils with 2" maximum diameter rock. Backfill materials shall be select native soils with 6" maximum diameter rock. If insulation is installed, use approximately 6" of sand or squeegee for the pipe zone materials above and beneath the insulation to protect it from breakage during backfill.

The Applicant for a building service line shall notify the District when the service is ready for connection to the water main, and the connection to said water main shall not be made until after inspection and approval by the District. The connection to the main shall be made in the presence of and approved by the District's Inspector. The line, valves and fittings must be leak-free under line pressure. The trench of each service line

must be kept open (not backfilled) from the building to the tap, until the completed line is accepted by the District's representative.

3.4 DOCUMENTATION

The Applicant shall submit a dimensioned sketch to the District, showing the location of the point of connection, relative to visible and reasonably permanent surface features, such as building corners, property pins or power/light poles. As-built drawings of the entire system, including curb-stops, shall be required at system dedication, or at the time that the applicant requests that water service to the structure/subdivision be turned on.

These designs, plans, and documents are reviewed for concept and general conformance to the Districts minimum standards only, and the primary responsibility for design adequacy is to remain with the Engineer of record. This review does not imply responsibility by either the Winter Park Ranch Water and Sanitation District or the District's Water System Engineer for completeness, accuracy or correctness of calculations. The review does not imply that quantities of items indicated on the Plans are the final quantities required. The review shall not be construed for any reason as acceptance of financial responsibility by the District for additional items and additional quantities of items shown that may be required during the construction phase.

Approved for construction within one year of the earliest of these dates:

By _____ Date _____
District Water System Engineer

By _____ Date _____
Winter Park Ranch W. & S. D.

Standard Approval Block

THESE DETAILS ARE PROVIDED FOR STANDARDIZATION PURPOSES ONLY. THIS DETAIL REPRESENTS MINIMUM DESIGN STANDARDS WHICH MAY REQUIRE UPGRADING FOR SPECIFIC APPLICATIONS. REFER TO W.P.R. W & S DIST UTILITY CONSTRUCTION STANDARDS AND MINIMUM DESIGN CRITERIA FOR SPECIFIC MATERIAL AND INSTALLATION REQUIREMENTS

Winter Park Ranch Water and Sanitation District - Water System
Standard Details Dwg. 2.1 JULY 2008

Modified July 2008 by Gary M. Cooper, P.E.

- A LOCATE WATER LINE BENDS
- B LOCATE WATER LINE TEES & CROSSES
- C LOCATE ALL VALVES, SERVICES & MAINS
- D LOCATE ANY SPECIALTY ITEMS. (E.G. FIRE HYDRANTS, METER VAULTS, ARV VAULTS, PRV VAULTS, COUPLINGS, ETC.)
- E NOTE DISTANCES TO EDGE OF PAVEMENT AND TO R.O.W. OR EASEMENTS
- F LOCATE ALL SERVICE TAPS AND LINES
- G NOTE ANY KNOWN R.O.W. AND EASEMENT INFORMATION.
- H NOTE FINAL INVERT ELEVATIONS W/ BENCHMARK ELEVATION REFERENCED.
- J NOTE LENGTH SIZE MATERIAL AND SLOPE OF LINE AS INSTALLED
- K NOTE DISTANCES BETWEEN UNDERGROUND UTILITIES
- L NOTE PERMANENT EASEMENT MONUMENTS AND PROPERTY CORNERS (PC) WHERE USED FOR TIES.
- M NOTE SERVICE STREET ADDRESSES.

DRAFT "AS RECORDED" DRAWING TO SCALE

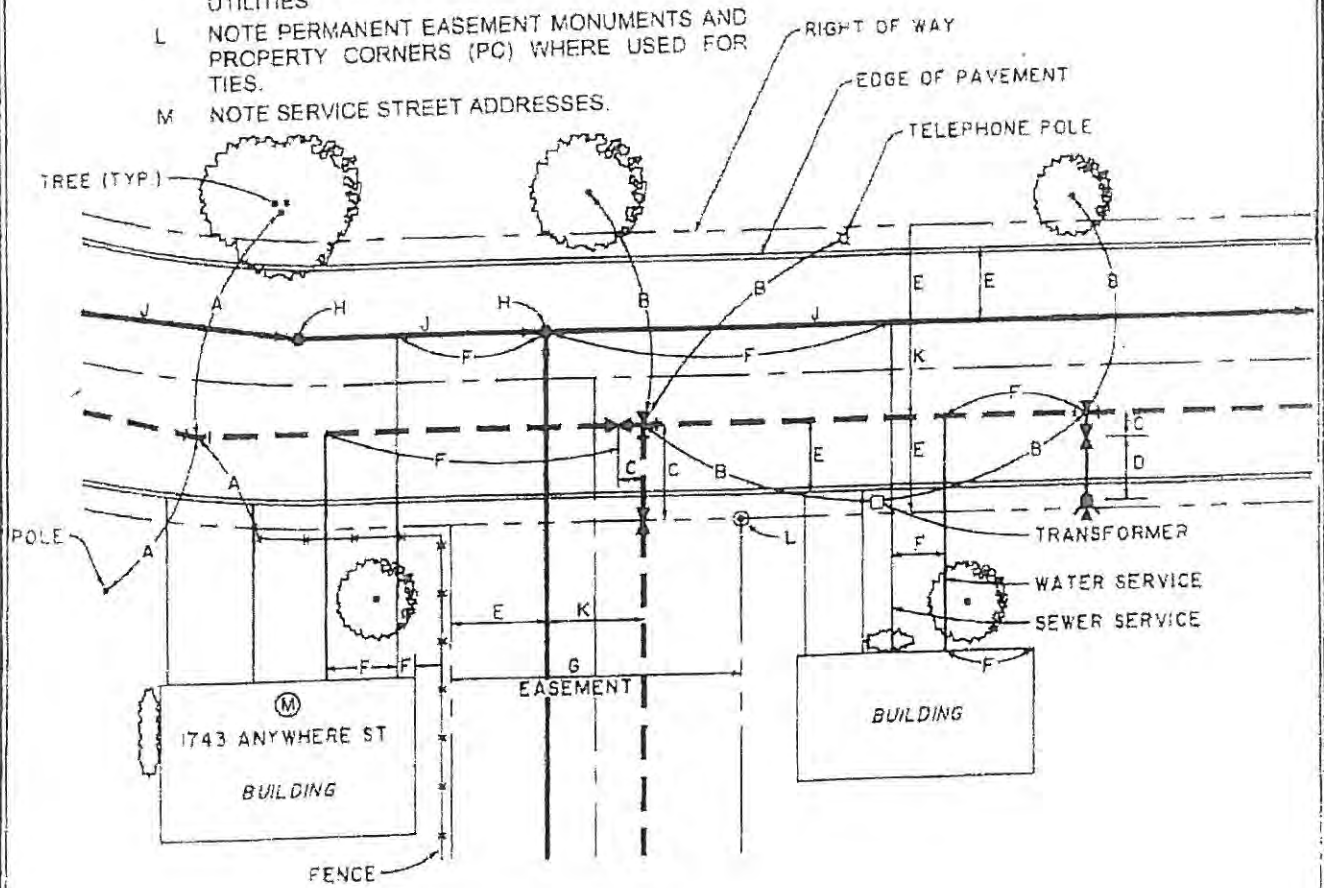

Typical "As Recorded" Drawing Information

THESE DETAILS ARE PROVIDED FOR STANDARDIZATION PURPOSES ONLY. THIS DETAIL REPRESENTS MINIMUM DESIGN STANDARDS WHICH MAY REQUIRE UPGRADING FOR SPECIFIC APPLICATIONS. REFER TO DISTRICT'S WATER UTILITY CONSTRUCTION STANDARDS AND MINIMUM DESIGN CRITERIA FOR SPECIFIC MATERIAL AND INSTALLATION REQUIREMENTS

Winter Park Ranch Water & Sanitation District - Water System
 Standard Details Dwg. 2.2 JULY 2008

Modified July 2008 by Gary M. Cooper, P.F.

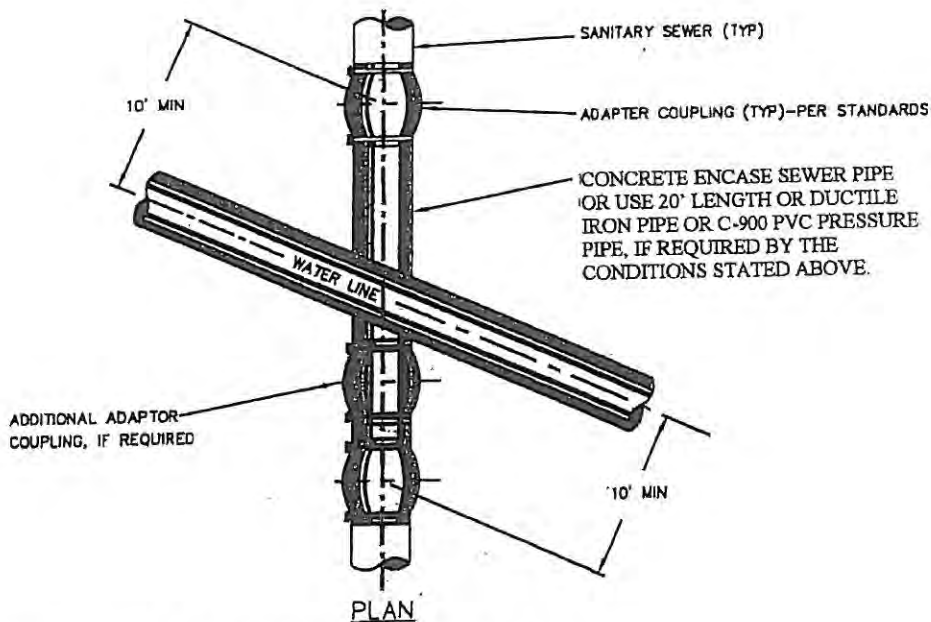
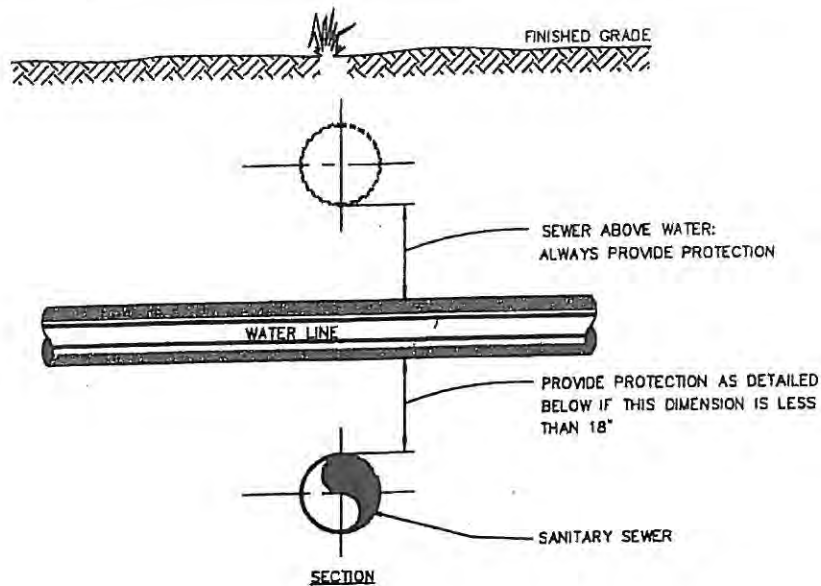

Sewer Crossing Water Line Detail

THESE DETAILS ARE PROVIDED FOR STANDARDIZATION PURPOSES ONLY. THIS DETAIL REPRESENTS MINIMUM DESIGN STANDARDS WHICH MAY REQUIRE UPGRADING FOR SPECIFIC APPLICATIONS. REFER TO DISTRICT'S WATER UTILITY CONSTRUCTION STANDARDS AND MINIMUM DESIGN CRITERIA FOR SPECIFIC MATERIAL AND INSTALLATION REQUIREMENTS.

Winter Park Ranch Water & Sanitation District - Water System
Standard Details Dwg. 2.3 JULY 2008

Modified July 2008 by Gary M. Cooper, P.E.

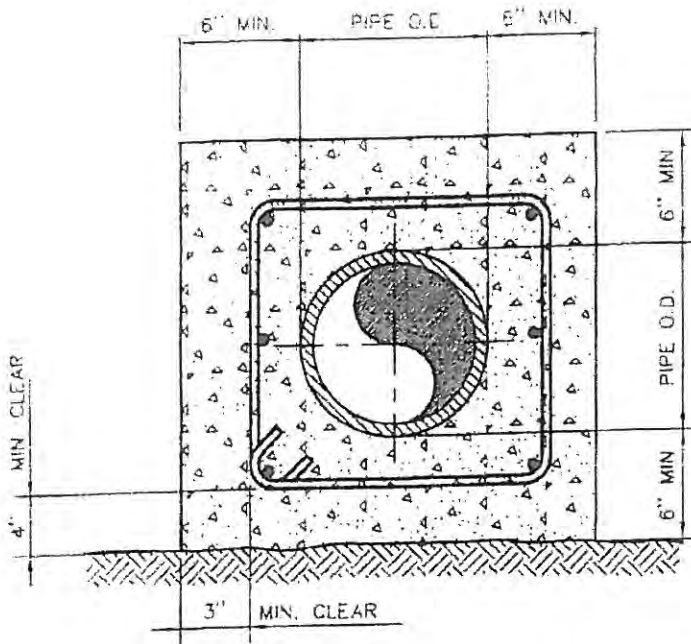

PIPE ENCASEMENT DETAIL

4--NO. 5 BARS CONTINUOUS FOR
8" PIPE AND 6--NO. 5 BARS
CONTINUOUS FOR 10" OR LARGER

NO. 4 TIES AT 18" O.C.

Pipe Encasement Detail - Sewer

THESE DETAILS ARE PROVIDED FOR STANDARDIZATION PURPOSES ONLY. THIS DETAIL REPRESENTS MINIMUM DESIGN STANDARDS WHICH MAY REQUIRE UPGRADING FOR SPECIFIC APPLICATIONS. REFER TO DISTRICT'S WATER UTILITY CONSTRUCTION STANDARDS AND MINIMUM DESIGN CRITERIA FOR SPECIFIC MATERIAL AND INSTALLATION REQUIREMENTS.

Winter Park Ranch Water & Sanitation District - Water System
Standard Details Dwg. 2.4 JULY 2008

Modified July 2008 by Gary M. Cooper, P.E.

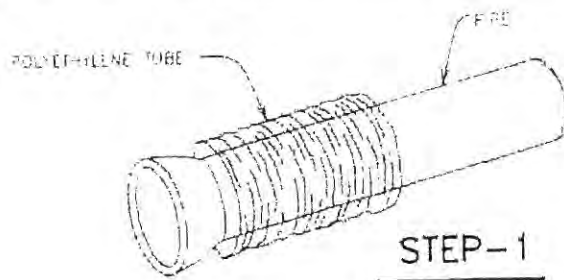

STEP-1

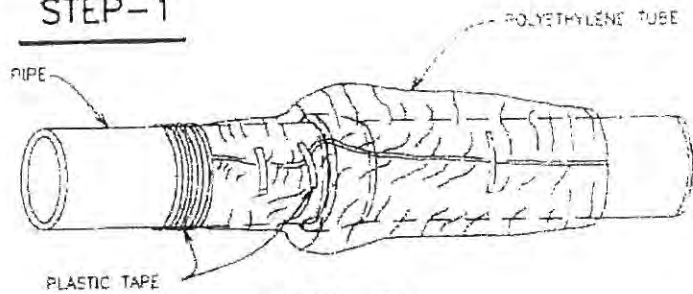

STEP-2

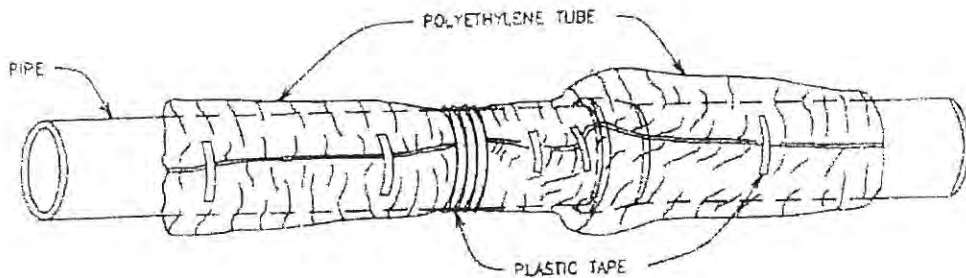

STEP-3

FIELD INSTALLATION-POLYETHYLENE WRAP

- STEP-1 PLACE TUBE OF POLYETHYLENE MATERIAL AROUND PIPE PRIOR TO LOWERING PIPE INTO TRENCH.
- STEP-2 PULL THE TUBE OVER THE LENGTH OF THE PIPE. TAPE TUBE TO PIPE AT JOINT. FOLD MATERIAL AROUND THE ADJACENT SPIGOT END AND WRAP WITH THREE CIRCUMFERENTIAL TURNS OF TWO-INCH WIDE PLASTIC TAPE TO HOLD PLASTIC TUBE AROUND SPIGOT END.
- STEP-3 ADJACENT TUBE OVERLAPS FIRST TUBE AND IS SECURED WITH PLASTIC ADHESIVE TAPE. THE POLYETHYLENE TUBE MATERIAL COVERING THE PIPE WILL BE LOOSE. EXCESS MATERIAL SHALL BE NEATLY DRAWN UP AROUND THE PIPE BARREL, FOLDED INTO AN OVERLAP ON TOP OF THE PIPE AND HELD IN PLACE BY MEANS OF PIECES OF THE PLASTIC TAPE AT APPROXIMATELY THREE TO FIVE FOOT INTERVALS.

Polyethylene Wrap Details

THESE DETAILS ARE PROVIDED FOR STANDARDIZATION PURPOSES ONLY. THIS DETAIL REPRESENTS MINIMUM DESIGN STANDARDS WHICH MAY REQUIRE UPGRADING FOR SPECIFIC APPLICATIONS. REFER TO DISTRICT'S WATER UTILITY CONSTRUCTION STANDARDS AND MINIMUM DESIGN CRITERIA FOR SPECIFIC MATERIAL AND INSTALLATION REQUIREMENTS.

Winter Park Ranch Water & Sanitation District - Water System
 Standard Details Dwg. 2.5 JULY 2008

Modified July 2008 by Gary M. Cooper, P.E.

NOTE:
PLUG SHALL BE MECHANICALLY RESTRAINED;

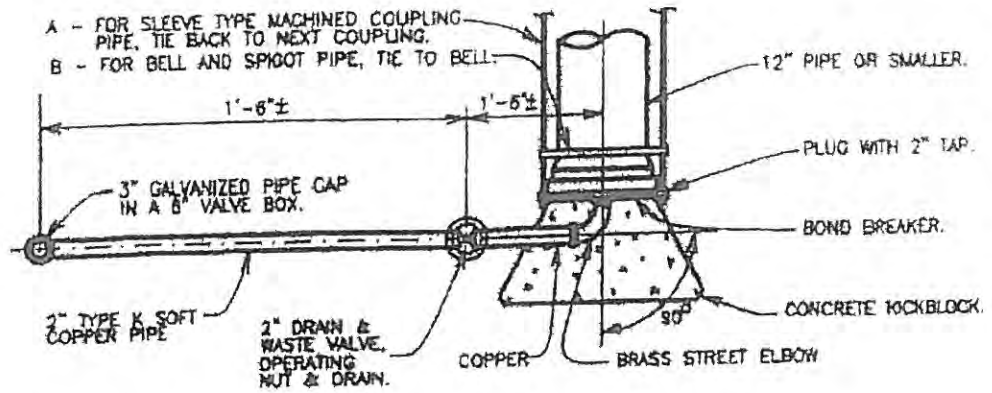

PLAN

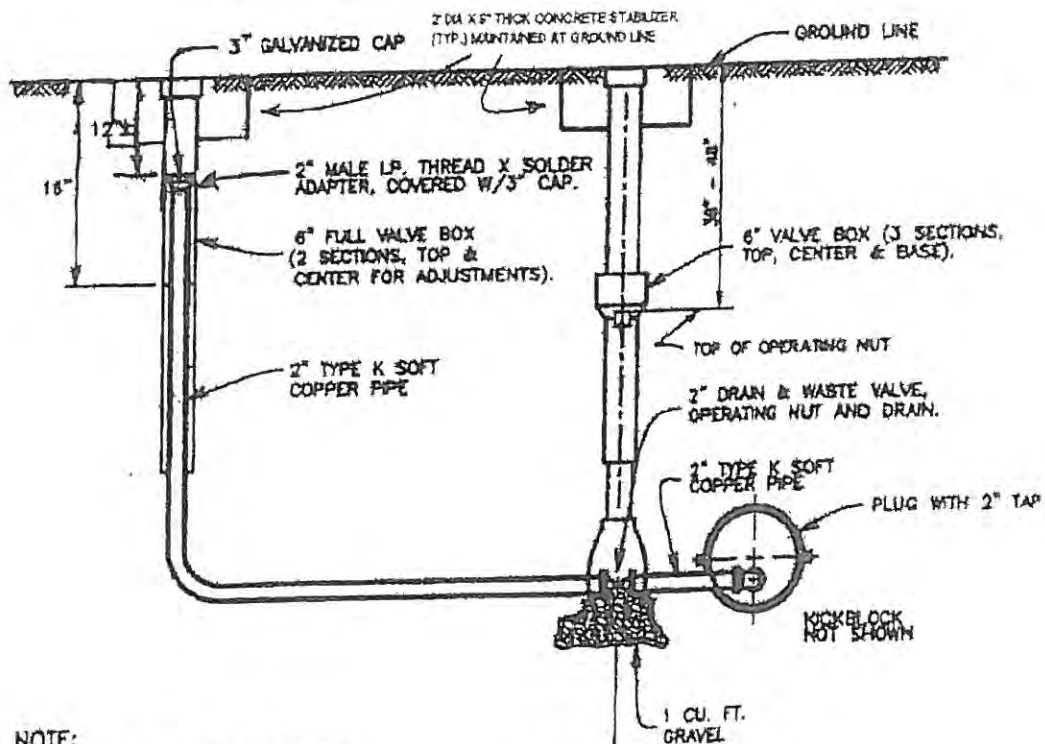

ELEVATION

NOTE:
AN ALTERNATIVE TO TYPE K COPPER
IS BRASS PIPE.

Blow-off Installation for 12" and Smaller Pipe

THESE DETAILS ARE PROVIDED FOR STANDARDIZATION PURPOSES ONLY. THIS DETAIL REPRESENTS MINIMUM DESIGN STANDARDS WHICH MAY REQUIRE UPGRADING FOR SPECIFIC APPLICATIONS. REFER TO DISTRICT'S WATER UTILITY CONSTRUCTION STANDARDS AND MINIMUM DESIGN CRITERIA FOR SPECIFIC MATERIAL AND INSTALLATION REQUIREMENTS.

Winter Park Ranch Water & Sanitation District - Water System
Standard Details Dwg. 2.6 JULY 2008

Modified July 2008 by Gary M. Cooper, P.E.

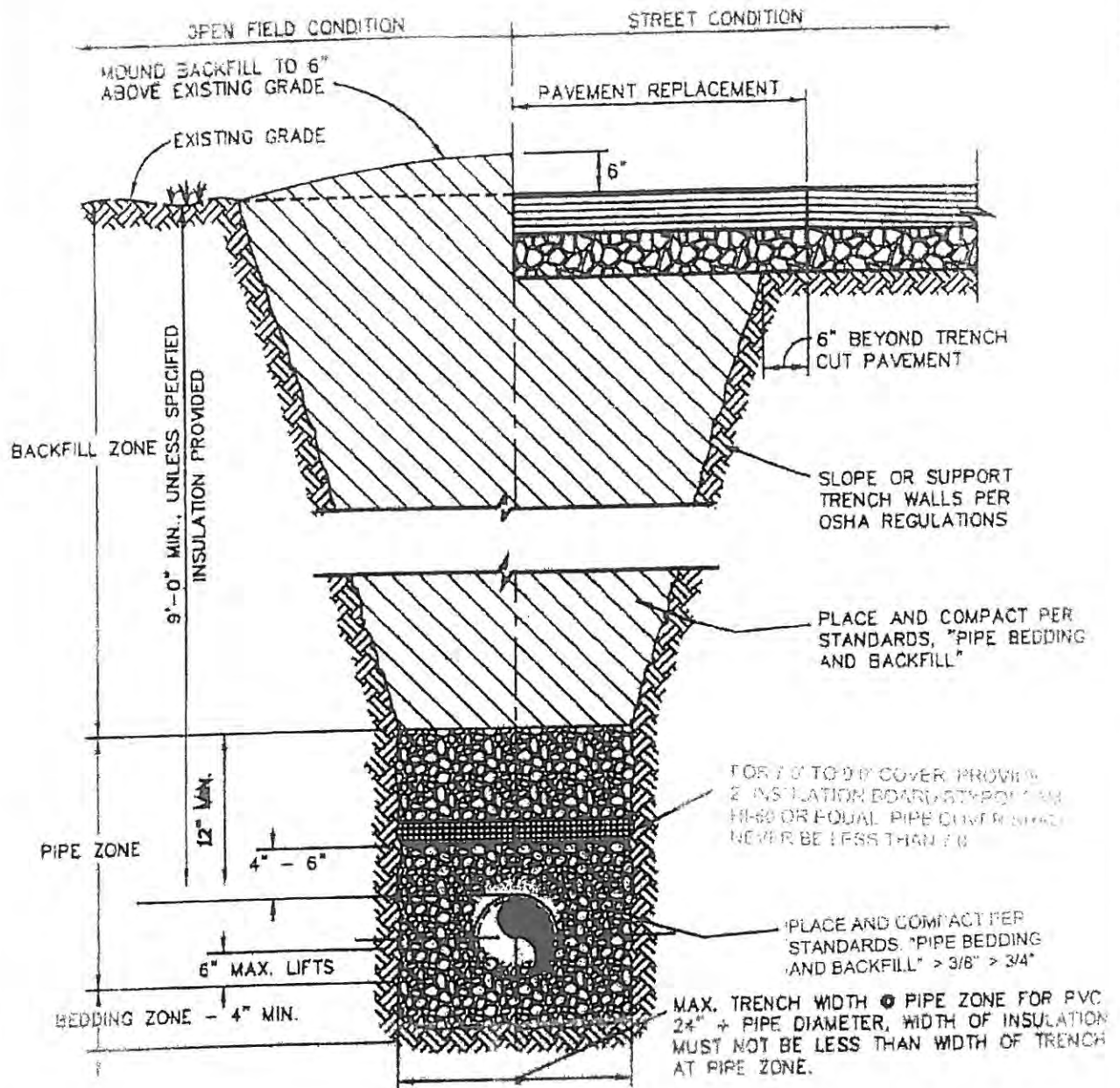

Water Main and Service Line Bedding and Backfill Detail

THESE DETAILS ARE PROVIDED FOR STANDARDIZATION PURPOSES ONLY. THIS DETAIL REPRESENTS MINIMUM DESIGN STANDARDS WHICH MAY REQUIRE UPGRADING FOR SPECIFIC APPLICATIONS. REFER TO DISTRICT 5 WATER UTILITY CONSTRUCTION STANDARDS AND MINIMUM DESIGN CRITERIA FOR SPECIFIC MATERIAL AND INSTALLATION REQUIREMENTS.

Winter Park Ranch Water & Sanitation District – Water System
 Standard Details Dwg. 2.7 JULY 2008

Modified July 2008 by Gary M. Cooper, P.E.

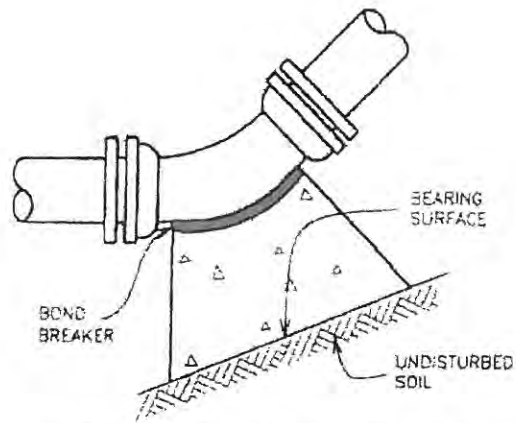

11¼°, 22½°, 45° AND 90° BENDS

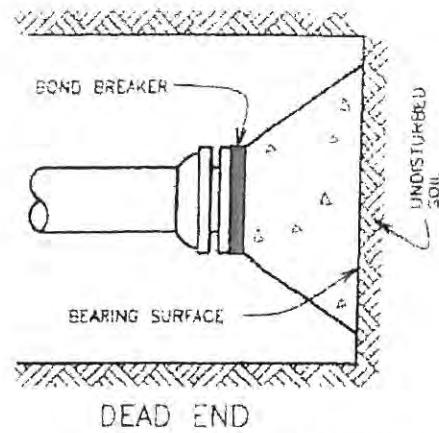

DEAD END

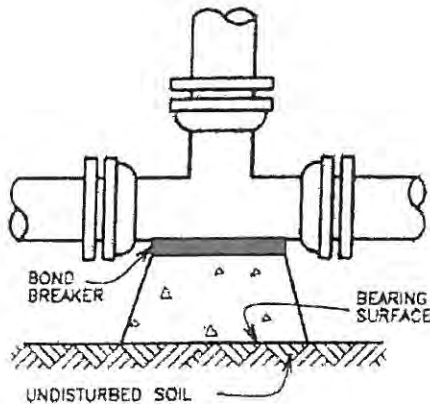

TEE

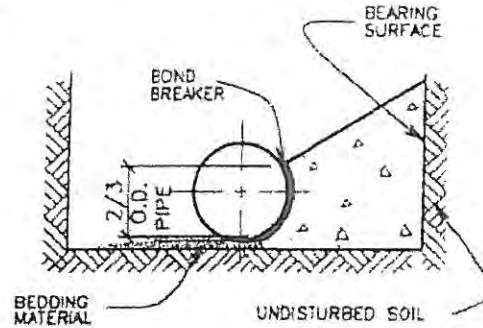

TYPICAL CROSS SECTION

MINIMUM BEARING SURFACE AREA
(IN SQUARE FEET)

SIZE OF PIPE	BENDS				TEE OR DEAD END
	11¼°	22½°	45°	90°	
4"	1.00	1.00	1.00	N.A.	1.50
6"	1.00	1.25	2.25	N.A.	3.00
8"	1.00	2.00	4.00	N.A.	5.25
12"	2.25	4.50	8.75	N.A.	11.25
16"	3.75	7.50	14.50	27.00	19.00
20"	5.00	10.00	19.50	35.50	25.00
24"	7.00	14.00	27.75	51.00	38.00

NOTES:

- 1.) BEARING SURFACES SHOWN IN CHART ARE MINIMUM.
- 2.) BASED ON 150 PSI INTERNAL PIPE PRESSURE PLUS WATER HAMMER, 4", 6", 8" AND 12" WATER HAMMER = 110 P.S.I., 16", 20" AND 24" WATER HAMMER = 70 P.S.I.
- 3.) BASED ON UNDISTURBED SOIL 3,000 psf OR BEARING CAPACITY.
- 4.) NA = NOT APPLICABLE.

Concrete Thrustblocks

THESE DETAILS ARE PROVIDED FOR STANDARDIZATION PURPOSES ONLY. THIS DETAIL REPRESENTS MINIMUM DESIGN STANDARDS WHICH MAY REQUIRE UPGRADING FOR SPECIFIC APPLICATIONS. REFER TO DISTRICT'S WATER UTILITY CONSTRUCTION STANDARDS AND MINIMUM DESIGN CRITERIA FOR SPECIFIC MATERIAL AND INSTALLATION REQUIREMENTS

Winter Park Ranch Water & Sanitation District - Water System
Standard Details Dwg. 2.8 JULY 2008

Modified July 2008 by Gary M. Cooper, P.E.

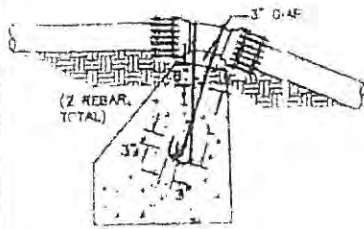

TYPE A RESTRAINT
11-1/4" & 22-1/2" VERTICAL OVER-BENDS

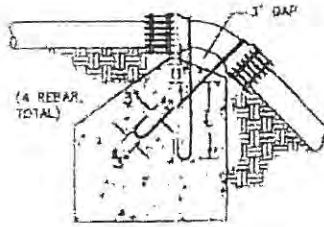

TYPE B RESTRAINT
45° VERTICAL UNDER-BENDS

PIPE SIZE NOMINAL DIAMETER - INCH	VERTICAL BEND DEGREES	NO. OF CU. FT. OF CONIC BLOTTING	DIAMETER OF REBAR, INCH	DEPTH OF ROOD IN CONCRETE, IN. FT.
4"	11-1/4"	5	5/8"	1.5
	22-1/2"	10	5/8"	2.0
6"	11-1/4"	11	5/8"	2.0
	22-1/2"	22	5/8"	2.0
8"	11-1/4"	20	5/8"	2.0
	22-1/2"	39	5/8"	2.0
12"	11-1/4"	45	3/4"	2.0
	22-1/2"	88	3/4"	3.0
18"	11-1/4"	78	3/4"	3.0
	22-1/2"	156	3/4"	4.0
20"	11-1/4"	123	3/4"	3.5
	22-1/2"	243	1"	4.0
24"	11-1/4"	177	3/4"	4.0
	22-1/2"	350	1"	4.0
30"	11-1/4"	277	1"	4.0
	22-1/2"	548	1-1/4"	4.0

PIPE SIZE NOMINAL DIAMETER - INCH	VERTICAL BEND DEGREES	NO. OF CU. YD. OF CONIC BLOTTING	DIAMETER OF REBAR, INCH	DEPTH OF ROOD IN CONCRETE, IN. FT.
4"	45°	0.7	5/8"	2.0
6"	45°	1.5	5/8"	2.0
8"	45°	2.7	5/8"	3.0
12"	45°	6.1	3/4"	4.0
16"	45°	10.8	3/4"	4.0
20"	45°	17.1	1"	4.0
24"	45°	24.8	1"	4.0
30"	45°	38.4	1-1/4"	4.0

NOTES:

- THRUST BLOCKS ARE REQUIRED IN ADDITION TO JOINT RESTRAINT.
- SPECIAL REQUIREMENTS:
 - THRUST BLOCKS FOR PIPE SIZES OR CONFIGURATIONS NOT SHOWN REQUIRE SPECIAL DESIGN.
 - BEARING AREAS, VOLUMES, AND SPECIAL THRUST BLOTTING DETAILS SHOWN ON DRAWINGS TAKE PRECEDENCE OVER THIS TYPICAL DETAIL.
 - REINFORCING STEEL BARS TO BE EPOXY COATED, AT LEAST 3/16" THICK MINIMUM YIELD STRENGTH OF REBAR IS 60,000 PSI.
 - RESTRAINT SIZING IS BASED UPON A MAXIMUM OPERATING PRESSURE OF 150 PSI, A TEST PRESSURE OF 200 PSI, AND A MINIMUM SOIL BEARING STRENGTH OF 2000 PSF. OPERATING PRESSURES IN EXCESS OF 150 PSI OR SOILS WITH LESS THAN 2000 PSF BEARING STRENGTH WILL REQUIRE SPECIAL DESIGN.
- FOR VERTICAL UNDER-BENDS FOLLOW HORIZONTAL THRUST BLOCK DETAIL.

Vertical Bend Anchor Blocks

Concrete Thrustblocks

THESE DETAILS ARE PROVIDED FOR STANDARDIZATION PURPOSES ONLY. THIS DETAIL REPRESENTS MINIMUM DESIGN STANDARDS WHICH MAY REQUIRE UPGRADING FOR SPECIFIC APPLICATIONS. REFER TO DISTRICT'S WATER UTILITY CONSTRUCTION STANDARDS AND MINIMUM DESIGN CRITERIA FOR SPECIFIC MATERIAL AND INSTALLATION REQUIREMENTS

Winter Park Ranch Water & Sanitation District – Water System
Standard Details Dwg. 2.8.2 JULY 2008

Modified July 2008 by Gary M. Cooper, P.E.

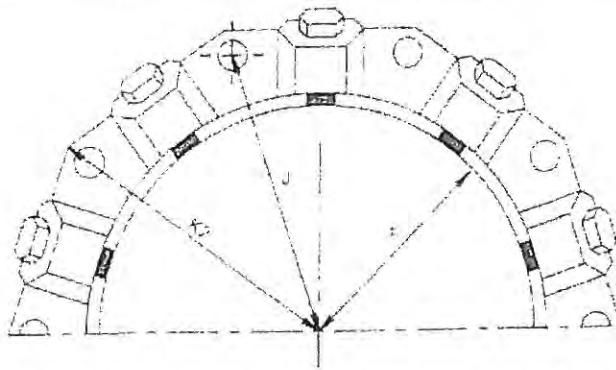

MECHANICAL JOINT RESTRAINT

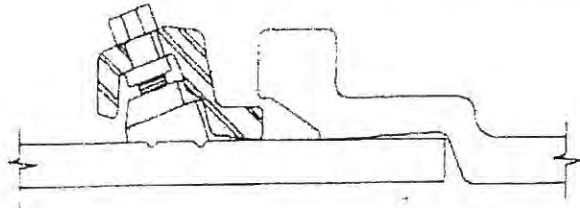

WEDGE DETAIL

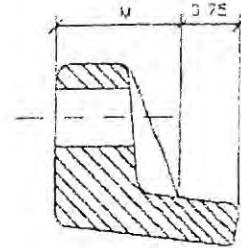

BOLT HOLE DETAIL

DIMENSIONS

	NOMINAL PIPE SIZE	NO. OF BOLTS	NO. OF WEDGES	K2 INCHES	J INCHES	F INCHES	M INCHES	
D I P	4"	4	2					D I P
	6"	6	3	11.12	9.50	7.00	0.88	
	8"	6	4	13.37	11.75	9.15	1.00	
	10"	8	5	15.62	14.00	11.20	1.00	
	12"	8	8	17.88	16.25	13.30	1.25	

NOTES:

- 1) AS MANUFACTURED BY EBBA IRON INC. (MECHANICAL 1100 SERIES), OR UNI-FLANGE (SERIES 1500)
- 2) DIMENSIONS FOR 16" AND 20" O.D. PIPE NOT SHOWN.
- 3) OTHER MECHANICAL JOINT RESTRAINT DEVICES MUST BE APPROVED BEFORE INSTALLATION.

Mechanical Joint Restraint Details

THESE DETAILS ARE PROVIDED FOR STANDARDIZATION PURPOSES ONLY. THIS DETAIL REPRESENTS MINIMUM DESIGN STANDARDS WHICH MAY REQUIRE UPGRADING FOR SPECIFIC APPLICATIONS. REFER TO DISTRICT'S WATER UTILITY CONSTRUCTION STANDARDS AND MINIMUM DESIGN CRITERIA FOR SPECIFIC MATERIAL AND INSTALLATION REQUIREMENTS.

Winter Park Ranch Water & Sanitation District - Water System
Standard Details Dwg. 2.9 JULY 2008

Modified July 2008 by Gary M. Cooper, P.E.

LENGTH OF RESTRAINED PIPE

PIPE SIZE	4"	6"	8"	12"	16"	20"	24"
FITTING	L	L	L	L	L	L	L
90° BEND TEE, PLUG	30'	45'	60'	86'	108'	132'	155'
VALVE	—	—	—	—	108'	132'	155'
45° BEND	9'	13'	18'	25'	32'	39'	45'
22½° BEND	1'	4'	5'	7'	8'	10'	12'
11¼° BEND	—	—	1'	2'	2'	3'	3'

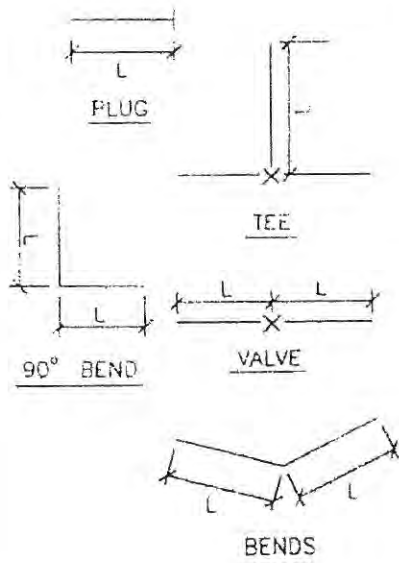

NOTES:

- 1.) LENGTH OF RESTRAINED PIPE MEASURED EACH WAY FROM VALVES AND BENDS
- 2.) CLAMPS, RODS & MEGALUGS NOT ALLOWED FOR 24" & LARGER PIPES
- 3.) D=DIAMETER, L=LENGTH, G=GRADE, M.S=MILD STEEL, H.S=HIGH STRENGTH
- 4.) BASED ON 150 PSI INTERNAL PRESSURE
- 5.) LENGTH REFERS TO THE AMOUNT OF PIPE WHICH MUST BE RESTRAINED TOGETHER AND IS NOT NECESSARILY THE LENGTH OF THE RODS
- 6.) LENGTH OF RESTRAINED PIPE CHART IS ALSO FOR THE LENGTH OF JOINT RESTRAINT FOR MEGALUGS, OR OTHER RESTRAINT SYSTEMS
- 7.) CROSSES MUST BE RESTRAINED IN ALL APPLICABLE DIRECTIONS.
- 8.) 12" AND SMALLER IN LINE VALVES AND TEES SHALL HAVE A MECHANICAL JOINT RESTRAINT DEVICE ON EACH SIDE OF THE FITTING OR VALVE
- 9.) IF A VALVE IS WITHIN DISTANCE "L" OF A FITTING, THE VALVE MUST BE TIED TO THAT FITTING
- 10.) A SECOND VALVE WILL BE REQUIRED TO BE CLOSED WHEN EXCAVATING NEXT TO EXISTING VALVE
- 11.) IF D.I.P. IS POLYETHYLENE WRAPPED, TIE RODS ARE TO BE ENCLOSED INSIDE THE WRAP.

Length of Restrained Pipe

THESE DETAILS ARE PROVIDED FOR STANDARDIZATION PURPOSES ONLY. THIS DETAIL REPRESENTS MINIMUM DESIGN STANDARDS WHICH MAY REQUIRE UPGRADING FOR SPECIFIC APPLICATIONS. REFER TO DISTRICT'S WATER UTILITY CONSTRUCTION STANDARDS AND MINIMUM DESIGN CRITERIA FOR SPECIFIC MATERIAL AND INSTALLATION REQUIREMENTS

Winter Park Ranch Water & Sanitation District - Water System
Standard Details Dwg. 2.10 JULY 2008

Modified July 2008 by Gary M. Cooper, P.E.

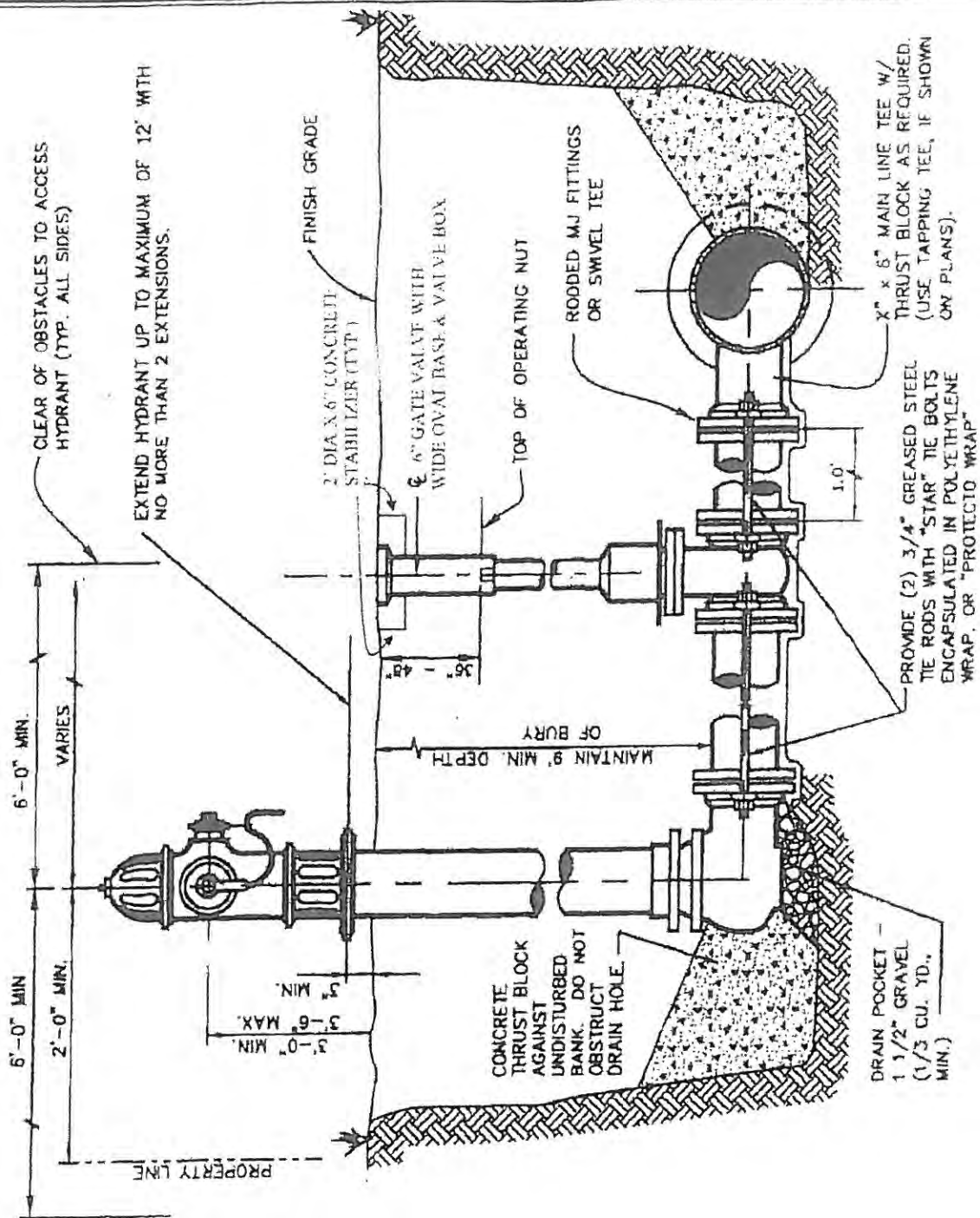

Standard Fire Hydrant Detail

THESE DETAILS ARE PROVIDED FOR STANDARDIZATION PURPOSES ONLY. THIS DETAIL REPRESENTS MINIMUM DESIGN STANDARDS WHICH MAY REQUIRE UPGRADING FOR SPECIFIC APPLICATIONS. REFER TO DISTRICT'S WATER UTILITY CONSTRUCTION STANDARDS AND MINIMUM DESIGN CRITERIA FOR SPECIFIC MATERIAL AND INSTALLATION REQUIREMENTS.

Winter Park Ranch Water & Sanitation District - Water System
Standard Details Dwg. 2.11 JULY 2008

Modified July 2008 by Gary M. Cooper, P.E.

NOTES:

1 - PLACEMENT OF STOP BOX IS TO BE A MAXIMUM OF 3 FEET INSIDE THE PROPERTY LINE (UNLESS OTHERWISE APPROVED).

2 - OWNER'S RESPONSIBILITY FOR REPAIRS EXTENDS TO THE CORPORATION STOP.

3 - THE DISTRICT OR OTHER PUBLIC ENTITIES ARE NOT RESPONSIBLE FOR ANY DAMAGE THAT MAY OCCUR DUE TO A LEAK ON A SERVICE LINE. THIS IS THE RESPONSIBILITY OF THE OWNER OF THE PROPERTY TO WHICH THE SERVICE LINE IS CONNECTED.

4 - IF THE DEPTH OF COVER IS LESS, USE INSULATION PER DRAWING 2.7. THE "GOOSE NECK" AT THE CORPORATION STOP MAY HAVE LESS COVER AND MAY REQUIRE INSULATION EVEN IF THE REST OF THE SERVICE LINE DOES NOT.

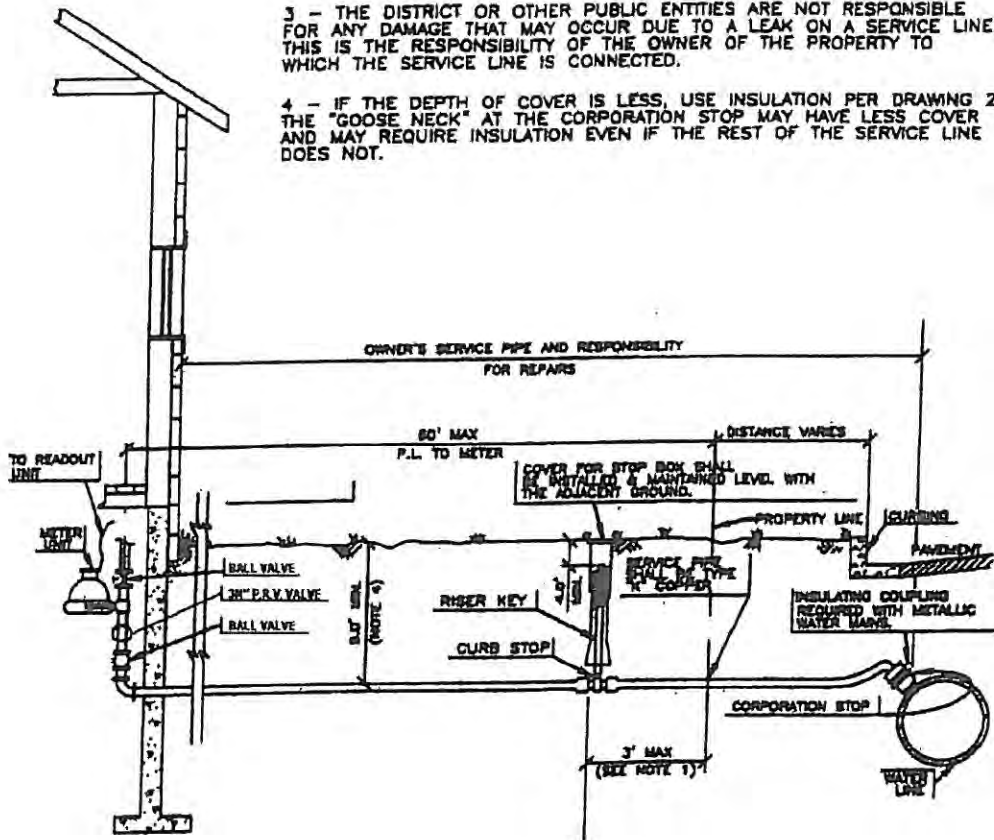

SERVICE LINE, STOP BOX AND INSIDE METER INSTALLATION

THESE DETAILS ARE PROVIDED FOR STANDARDIZATION PURPOSES ONLY, THIS DETAIL REPRESENTS MINIMUM DESIGN STANDARDS WHICH MAY REQUIRE UPGRADING FOR SPECIFIC APPLICATIONS. REFER TO DISTRICT'S UTILITY CONSTRUCTION STANDARDS AND MINIMUM DESIGN CRITERIA FOR SPECIFIC MATERIAL AND INSTALLATION REQUIREMENTS.

Winter Park Ranch Water & Sanitation District – Water System
Standard Details Dwg. 2.12 JULY 2008