

# SEWER UTILITY

## CONSTRUCTION STANDARDS AND MINIMUM DESIGN CRITERIA FOR WINTER PARK RANCH WATER SANITATION DISTRICT

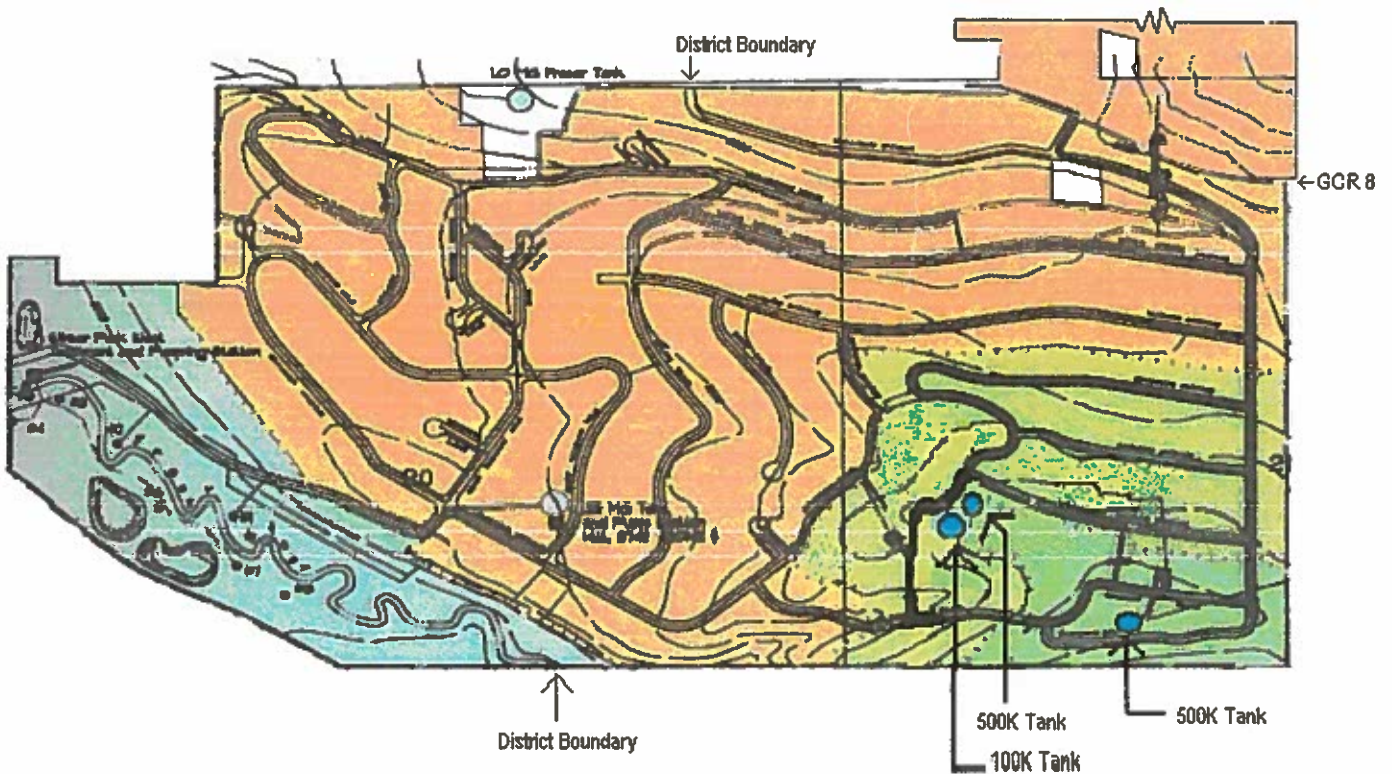

PREPARED BY:



Modified by Gary M. Cooper, P.E.

APRIL 2009

*JW 7-21-09*

**WINTER PARK RANCH WATER & SANITATION DISTRICT  
SANITARY SEWER CONSTRUCTION STANDARDS  
AND MINIMUM DESIGN CRITERIA**

**TABLE OF CONTENTS**

	<u>PAGE</u>
<b>SECTION 1 - GENERAL/EXPLANATORY MATERIAL</b>	
1.1	Applicability ..... 1
1.2	Definitions ..... 1
<b>SECTION 2 - LOCAL COLLECTION SYSTEM STANDARDS</b>	
2.1	General..... 3
2.2	Drawings ..... 3
2.3	Required Easements ..... 4
2.4	Design/Sizing ..... 4
2.5	Sanitary Sewer System Materials..... 6
2.6	Installation ..... 7
2.61	Sewer Installation..... 7
2.62	Manholes..... 8
2.63	Underdrains..... 9
2.64	Pipe Bedding and Backfill ..... 9
2.7	Flushing, Testing and Acceptance ..... 15
2.71	Sanitary Sewer Line Testing..... 15
2.71a	Pipeline Flushing ..... 15
2.71b	Alignment and Grade..... 15
2.71c	Leakage Testing by Exfiltration ..... 15
2.71d	Leakage Testing by Infiltration..... 16
2.71e	Low Pressure Air Test..... 16
2.71f	Deflection ..... 19
2.72	Testing Manholes..... 20
2.72a	Visual Examination ..... 20
2.72b	Leakage Test ..... 20
2.73	Deferred Television Inspection ..... 21
2.8	Checklist..... 21

**WINTER PARK RANCH WATER & SANITATION DISTRICT  
SANITARY SEWER CONSTRUCTION STANDARDS AND MINIMUM DESIGN CRITERIA**

**TABLE OF CONTENTS**  
(Continued)

	<u>PAGE</u>
<b>SECTION 3 - SEWER SERVICE LINE STANDARDS</b>	
3.1	General .....23
3.2	Sanitary Sewer Service Connections .....23
3.21	Sizing/Capacity .....23
3.22	Service Connection.....24
3.23	Pipeline Materials .....25
3.24	Service Line Installation.....25
3.3	Documentation.....25
<b>APPENDIX A - COLLECTION SYSTEM STANDARD DETAILS</b>	
A.1	Standard Approval Block
A.2	Typical As-Recorded® Drawing Information
A.3	Standard Precast Concrete Manhole
A.4	Shallow Precast Concrete Manhole
A.6	Sewer Main Bedding & Backfill Detail
A.7	Pipe Encasement Detail - Sewer
A.8	Sewer Crossing Water Line Detail
<b>APPENDIX B - SERVICE LINE STANDARD DETAILS</b>	
B.1	Sewer Service Connection Detail
B.2	Service Line Cleanout Detail

**WINTER PARK RANCH WATER & SANITATION DISTRICT**  
**Sanitary Sewer Utilities**  
**Construction Standards and Minimum Design Criteria**

**SECTION 1**  
**GENERAL / EXPLANATORY MATERIAL**

**1.1 APPLICABILITY**

These technical standards are to be applied in conjunction with the other administrative and procedural requirements of the Winter Park Ranch Water & Sanitation District.

**1.2 DEFINITIONS**

Unless the context specifically indicates otherwise, the meaning of terms used herein shall be as follows:

Actual Cost shall mean all direct costs applicable to the construction of a given facility, including surveys, preliminary and design engineering, construction, inspection, administrative, regulatory agency fees, bond fees, all required easements and/or rights of way, plan approval fees, "as-built drawings, attorneys' fees and other costs necessary for completion.

Applicant shall mean the person(s), firm, joint venture, partnership or corporation which is requesting service from the District. In this document, the words "applicant" and "developer" have been used interchangeably.

Board and Board of Directors shall mean the governing body of the Winter Park Ranch Water & Sanitation District.

Contractor shall mean the entity working on behalf of the developer to construct utilities or other physical improvements.

Customer shall mean any person, company, corporation or governmental authority or agency authorized to use the public water, irrigation, sewer or drainage systems under a permit issued or otherwise authorized by the Board of Directors or the District Manager.

Developer shall mean the person(s), firm, joint venture, partnership or corporation which is the owner or operator of land and which seeks to have the land served by the District.

District shall mean the Winter Park Ranch Water & Sanitation District or the Board of Directors of the District.

Engineer shall mean the engineering firm, or duly authorized representative, designated by the District to act on its behalf in all engineering and related matters. This item includes an Inspector employed by the Engineer.

Engineer of Record shall mean the Professional Engineer, registered with the State of Colorado, who is responsible for the design of utilities or other improvements on behalf of the Developer.

EQR is an abbreviation for Equivalent Residential Unit which is an average single-family detached residence or the equivalent, from a systems demand standpoint.

Inspector shall mean the Manager, Superintendent, Engineer, agent, officers, employees of the District or other person so designated by the Manager to perform inspections pursuant to the Districts' Rules and Regulations and these Construction Standards.

Local Facilities are those facilities generally designed primarily to serve individual subdivisions or plats. Examples are: water distribution systems and collector sewer lines.

Manager shall mean Manager of the District, or, the Manager's duly authorized agent.

Oversize Costs This item is applicable to part of the costs of a sewer collection line to be installed within, or for, a subdivision; but which the District has also assigned a transmission function which results in the need for a larger pipeline. Oversize costs are the difference between the actual costs of the size line required by the District and the size required by the Developer; however, for purposes of determining oversize, the minimum size shall be assumed to be 8-inch diameter for sewer. Engineer and inspection costs are assumed to be proportional to estimated or experienced costs. Incremental costs will be allowed for line fittings, manholes and other appurtenances (if a size increase is required).

Owner shall mean the land's record title holder or lessee with planning powers.

Permit shall mean written permission of the Board of Directors authorizing connection to a sewer main of the District granting Applicant a license to use the system or to receive

service from the system owned, operated or served by the District as the same is defined in the Rules and Regulations of the District.

Person shall mean any individual, firm, company, association, society, corporation or group.

Preliminary Acceptance shall mean formal notification by the District to the Applicant that all the requirements of Section 2.8 "Checklist" have been met.

Sewage shall mean any liquid waste containing animal or vegetable matter in suspension or solution from residences, commercial buildings, institutions, and industrial establishments.

Sewer or Sewer Main shall mean a District-owned sewer pipeline, carrying sanitary sewage or approved industrial wastes only, and shall be installed in a public street or easement.

Sewer Service Line shall mean the privately owned sewer line extending from the building drain to the sewer main and shall include the tap onto the sewer main.

Shall is mandatory; "May" is permissive.

## **SECTION 2 LOCAL COLLECTION SYSTEM STANDARDS**

### **2.1 GENERAL**

Local sewerage facilities are considered to be engineered improvements which are designed for specific applications. All designs, drawings and specifications must be prepared by, or under the direction of a Professional Engineer registered in Colorado, whose seal must be on a record set of documents. Local collection systems are the responsibility of the Developer, who is responsible for design and construction and the costs thereof and for payment of actual costs of design reviews and other reviews and inspections provided by the District.

The standard details and specifications contained herein are minimum design standards which the District will accept in order to facilitate perpetual operation and maintenance procedures. In addition to these standards, the Applicant's Engineer must also design in accordance with the minimum standards of other regulatory agencies. In cases of conflicting standards or requirements, the District or its Engineer will determine which requirements govern. Review and approval of local facilities designs by the District or its Engineer shall not relieve the Engineer of Record from responsibility for adequate design.

Contractors working for the District must perform all work between 7:30 a.m. and 5:00 p.m., Monday through Friday. No work will be allowed after these hours or on Saturday, Sunday or Holidays without advance approval from the District. Work performed outside of regular week day hours will require a District Inspector to be on-site to oversee the project. The Inspector's time will be charged to the contractor at a rate of time and one half of the inspectors total compensation.

No contractor shall tap a District water or sewer line outside of Monday through Thursday. A District Inspector must be present to approve all taps and service line before any trench is back-filled. If a tap or service line is back-filled without being inspected by the District, it must be dug up and exposed so that the District Inspector can approve it.

All construction work shall be performed between May 15 and October 15, or as allowed by the Grand County Road and Bridge Department.

### **2.2 DRAWINGS**

Unless otherwise approved by the District's Engineer, all design drawings shall be on 24" x 36" mylar, using ink for all background information and permanent pipeline work. Drawing scale for area plans shall be 1" = 50 ft.

**Prior to the construction or installation of any Local Facilities, the Developer shall submit Design Documents to the District for review and approval.** Three (3) sets of blue-line copies are to be submitted. Each construction drawing set shall have an "approval block" affixed thereto which provides for the signatures of authorized representatives of the District and the District's Engineer. The "approval block" shall be a facsimile of that appended to these Construction Standards, Drawing A.1. **Construction may not begin until the District has issued written approval of the Design Documents.**

After completion of construction, the Developer shall provide to the District a complete set of record drawings ("as-builts") for the facilities. The record drawings shall show adequate dimensioned ties to reasonably permanent surface features for all buried facilities to allow for future locating. The record drawings shall be mylar transparencies suitable for blue line reproductions. The Developer shall also submit an electronic media copy to the District's Engineer in AutoCAD format, using control points provided by the District. (ver. 14, or other version approved by the Engineer). As-builts shall be in general conformity to the Standard Drawing "Typical Record Drawing Information," Drawing A.2.

## **2.3 REQUIRED EASEMENTS**

Where Local Facilities are to be located out of the public right-of-way, the Developer shall be responsible for obtaining easements required for the construction, maintenance, and operation of the facilities. The District will not accept alignments that could present access or construction problems in present or in the future (e.g., steep slopes or difficult vehicular access).

The legal description for the easements shall be prepared by a Professional Land Surveyor, registered in the State of Colorado. Easements shall be in a form acceptable to the District and shall be shown on the construction drawings. **The District will not approve the Contract Documents until all required easements have been deeded to the District.**

In general, the minimum width of easements for pipelines shall be 30 feet. Temporary construction easements shall have a minimum width of 40 feet. Wider easements may be required for deep sections of pipeline, multiple lines, storm sewers, or where otherwise required by the District. In general, the easement to contain a water line and a sewer line shall be no less than 50 feet.

## **2.4 DESIGN / SIZING**



Collection sewer system design is intended to provide gravity service only. Before the start of design, the Developer is to contact the District's Engineer to confirm the connection point with the existing sewer system. Sewer line sizing is to be approved by the District's Engineer. The District may direct the Developer to provide sewer line capacity in excess of the Developer's requirements. In such cases, the District may reimburse the developer for the incremental cost of the oversize. Sewage lift stations and force mains will not be permitted unless specifically authorized by the District.

Collection sewers shall be designed to carry not less than the projected peak flow rates flowing half full (safety factor = 2.0), unless otherwise approved by the District's Engineer. The minimum size collection sewer shall be 8" diameter. Sewers shall be so designed and constructed to give mean velocities, when flowing full, of not less than 2 feet per second.

Normally, unless otherwise approved by the District's Engineer, sewer lines shall be located on the "cut" side of the street to the center of the street. Sewers shall generally be designed with sufficient depth to serve basements by gravity. The minimum cover shall be 7 feet from top of sewer to finished grade. A minimum of 5 feet of cover will be allowed (for short distances) if at least 2 inches of an approved pipeline insulation is provided. See Drawing A.6 for detail.

Water and sewer lines shall have 10 feet minimum (outside diameter to outside diameter) of horizontal separation. Where this separation is impractical, the District may permit other separation requirements, in accordance with applicable standards. If a water line passes under a sewer main or service, or if it lies within 10 feet of the sewer, the sewer is to be encased per Drawing A.7 or modified to have no bell construction per Drawing A.8. Using pressure-rated pipe for the sewer may also be an acceptable remedy (such as one twenty foot length of C-900 pipe).

Where required for structural reasons or to protect potable water pipelines, the sewer shall be encased in reinforced concrete having design characteristics not less than those shown on the Drawing A.7, "Pipe Encasement Detail."

When specifically authorized by the Engineer, other encasement alternatives may be permitted, per Drawing A.8. For potable water pipeline crossings, a 20-foot length of specified PVC C-900 or C-905 (as appropriate) or DIP Class 52 (or higher) may be used for the gravity sewer line. Center a 20-foot length on the water pipe with watertight transition couplings for connections to the sewer. Manholes shall be located at a maximum spacing of 400 ft. center-to-center and also at changes in sewer pipeline alignment and/or grade and at the end of each line. Sewers shall be laid with uniform slope between manholes.

Interior drop manholes (per Drawing A.5) are to be provided for any pipeline whose invert entering the manhole is greater than 18" above the invert out.

## **2.5 SANITARY SEWER SYSTEM MATERIALS**

**Pipe:** Sewer pipe and fittings, 15 inches and smaller, shall be solid wall polyvinyl chloride (PVC), SDR 35 minimum thickness conforming to ASTM D3034. PVC pipe, 18-36" diameter shall conform to ASTM F679, solid wall pipe. Joints shall be of the "slip on" type with integrally cast bell having an elastomeric gasket. For non-standard sewer line applications (e. g.: steep terrain; force mains; crossings of streams, ditches or drainages), the District's Engineer will issue project-specific requirements on request.

**Pipeline Insulation:** For normal depth of bury and overburden, the insulation shall be Dow STYROFOAM 60, or approved equivalent. For heavy traffic or other high-compaction service, the insulation shall be Dow STYROFOAM 115.

**Manholes:** Manhole bases, barrels and tops shall be precast concrete units conforming with ASTM C-478. Concrete for manhole bases and other similar items shall have a 28-day compressive strength of not less than 3,000 psi. All reinforcement required shall be standard deformed reinforcement conforming to the requirements set forth in ASTM A615, Grade 40. Precast concrete units shall be Oldcastle Precast, as provided by Amcor Precast of Littleton, CO or approved equal.

The top section required for change of diameter shall be eccentric cone or flat slab if approved by the Engineer or shown on the Standard Details. To bring the manhole cover to the correct elevation, the adjustment section of each manhole shall be pre-cast concrete grade adjustment rings. These rings shall be not less than 6 inches wide and furnished in heights to allow for 1-inch adjustment. Total adjustment height with grade rings, shall not exceed 8 inches.

Rubber Boots for connecting PVC pipe to manhole sections shall be specifically manufactured for that purpose. The rubber boots shall be provided by the pipe manufacturer. The rubber boots shall be positioned in place prior to the concrete in the pre-cast unit being poured.

**Manhole Joints:** the joints between precast manhole sections are to be sealed with Rub-R-Nek LTM by Henry Company, or approved alternate gasket material.

**External Joint Sealing:** In addition to the gasket material used within the joints between sections of the manhole, an external joint wrap is required. Wrap is to be no less than 16" wide and is to be:

- 1) ConSeal CS-202 Butyl Rubber external joint wrap, or ConWrap CS-212 External Joint Wrap, as manufactured by Concrete Sealants, Inc.; New Castle, Ohio, or
- 2) Cadillac External Pipe Joint, as manufactured by Cadillac Inc., Escanaba, Michigan, or
- 3) EZ-WRAP Rubber Butyl adhesive tape as manufactured by Press-Seal Gasket Corporation, Fort Wayne, Indiana, or
- 4) Rub-R-Nek external concrete joint wrap as manufactured by Henry Company, Houston, Texas.
- 5) Or an approved equal.

Manholes for sewers of 15" diameter or less shall have a minimum inside diameter of 4 feet. Consult the District's Engineer for requirements for larger sewers. Manholes shall be constructed and installed in accordance with the appended drawings, "Standard Precast Concrete Manhole", "Shallow Precast Concrete Manhole", and "Drop Detail for Manhole", Drawings A.3, A.4, and A.5.

The pipe penetration into the manhole shall be sealed by a flexible watertight boot system. Acceptable products include: PSX Positive Seal, as manufactured by Press-Seal Gasket Corp., Fort Wayne, Indiana; Kor-N-Seal, as manufactured by NPC, Inc., Milford, NH, or approved alternative. Where grades are too steep to allow a "boot" system, the District Engineer will approve an alternative system.

**Manhole Frames and Covers:** Manhole frames and covers shall be cast iron with the word "SEWER" cast on the cover, and are to be of gasketed and bolted design. Product shall be Neenah Catalog No. R-1915-G2, or H2, Type P, or approved equal. Clear opening to be 23" diameter, minimum. If the District determines that a bolted lid is required for specific installations, the bolts are to be installed. Unless otherwise specified by the District, manhole frames shall be gasketed, but left unbolted. Lids must have concealed pick holes, per Neenah Type "F".

Manhole Steps shall be injection-molded polypropylene encapsulating a 1/2" grade 60 reinforcing rod. Shall be M.A. Industries step, Model PS-1PF, as provided by Amcor Precast, Littleton, CO, or approved equal.

## **2.6 INSTALLATION**

### **2.61 Sewer Installation**

The sewer system shall be installed in a thorough, workmanlike manner in accordance with the Design Documents that have been approved by the District. The minimum bedding and backfill requirements shall be as shown on the appended Drawing A.6, "Sewer Main and Service Bedding and Backfill Detail".

The minimum cover shall be 7 feet from top of sewer line to finished grade. Pipelines shall not be placed deeper than 10 feet without prior approval by the District. A minimum of 5 feet of cover will be allowed (for short distances) if at least 2 inches of an approved pipeline insulation is provided, per Drawing A.6. If insulation is installed, use approximately 6" of sand or squeegee for the pipe zone materials above and beneath the insulation to protect it from breakage during backfill.

If the bottom of the excavation is soft or unstable, and in the opinion of the District, is not a satisfactory support for the pipeline, further depth and/or width shall be excavated and refilled to 6" below the pipe outside diameter (excluding bells) with Trench Stabilization Material, as specified in Pipe Bedding and Backfill.

Each pipe length and fitting interior, interior surface of bells, and exterior surface of spigots shall be cleaned of all foreign material before placing it in the trench and shall be kept clean all times thereafter. Each item must also be examined for cracks and other defects before installation.

Pipe shall be cut, only whenever necessary, to conform to location of manholes or connections. All cuts shall be straight, true, and at right angles to the axis of the pipe unless otherwise noted or directed by the Engineer. The cutting process shall leave a smooth end without damaging the pipe. All burrs shall be removed from the ends of cut pipe, and the end chamfered and lightly rasped or filed. All tools used in cutting pipe shall be subject to the Engineer's approval. The manufacturer's requirements for lubrication and gaskets must be followed.

Pipe laying shall proceed upgrade with the spigot ends of pipe pointing in the direction of the flow, unless otherwise approved by the Engineer. Each pipe length shall be laid true to line and grade in such manner as to form a close concentric joint with the adjoining pipe and to prevent sudden offsets to the flow line. Pipe shall be laid in an unwatered trench and shall not be used for draining water from the trench. Pipes are to be kept clean by capping or plugging ends.

## **2.62 Manholes**

Manholes shall be constructed to conform to the details shown in the Standard Details. The invert channels shall be smooth and semi-circular in shape, conforming to the inside of the incoming and outgoing sewer pipelines. Changes in direction of flow shall be made with a smooth curve of as large a radius as the size of the manhole will permit. Changes in size and grade of the channels shall be made gradually and evenly. Where differences in invert elevations exist, sloped flow channels shall be formed so the sewage does not undergo a vertical drop. The invert channels may be formed directly in the concrete of the manhole base. The floor of the manhole outside of the channel shall be smooth and shall slope toward the channels not less than 1 inch per foot nor more than 2 inches per foot. The top circumference of the base shall be finished level and smooth to permit obtaining a watertight joint between the precast manhole sections and the cast in place base. The manhole covers shall be set with their tops at the grades set forth in the Standard Details.

When a manhole top is above the ground line, compacted backfill shall be placed around the exposed section as shown on the Standard Details. Manhole tops without bolted, gasketed covers shall not be set at or below surrounding grade, except in paved roadways. The site shall be graded so that drainage is away from the manhole.

Each joint of the precast manhole barrel shall have at least one continuous gasket placed on the lower ledge before the barrel immediately above is lowered into place.

If a poured-in-place base is allowed, joints between the precast manhole barrel sections and the cast in place manhole bases shall use two continuous gaskets and shall be grouted inside and outside using approved non-shrink grout. With a poured-in-place base, the surface of the precast barrels and the cast in place bases shall be smooth and sound. The joint surfaces shall be cleaned to remove any concrete projections or dirt which may prevent a water-tight seal from being established. The joints shall be prepared and the gaskets shall be placed in accordance with the manufacturer's recommendations.

External Joint Sealing Wrap is to be applied to clean concrete surfaces per manufacturer's requirements and must be applied immediately prior to backfilling, so when backfill is compacted the earth pressure forces bituminous wrap into concrete surfaces. Temperature of manhole sections and of backfill materials must be above 40 deg. F from time of applying wrap to time of backfilling. No manholes shall be allowed deeper than 20 feet nor shallower than 7 feet.

### **2.63 Underdrains**

The District does not allow the use of underdrains laid in the same trench as a sanitary sewer line.

### **2.64 Pipe Bedding and Backfill**

- a. Trench Zones. The terms "Bedding Zone", "Pipe Zone" and "Backfill Zone" shall refer to the trench zones identified in the Standard Details, Sewer Main Bedding and Backfill Detail.
  - (1) Bedding zone. The Bedding Zone shall consist of all material placed below the pipe invert or, when permitted, the native materials graded and prepared for direct placement of the pipe.
  - (2) Pipe zone. The Pipe Zone shall consist of all material placed above the pipe invert to an elevation shown on the details.
  - (3) Backfill zone. The Backfill Zone shall consist of all material above the Pipe Zone.

b. **Material.** All bedding and backfill material shall have the approval of the Engineer. All bedding and backfill material shall be free of frozen material, organic material and debris. The materials to be used in each trench zone are indicated on the Standard Details and these materials are described below. All materials may be subject to gradation tests and compaction tests prior to approval of the use of that material. The test results shall be submitted to the Engineer for approval and verified as to their accuracy. These tests shall be performed at no cost to the District or its agents.

- (1) **Sand bedding or sand backfill material.** This material shall be a clean, well-graded sand and shall conform to the following limits when tested by means of laboratory sieves:

**Well-Graded Sand**

Sieve Size	Total Percent Passing by Weight
3/8-inch	100
No. 4	70 - 100
No. 8	36 - 93
No. 16	20 - 80
No. 30	8 - 65
No. 50	2 - 30
No. 100	1 - 10
No. 200	0 - 3

- (2) **Roadbase bedding material or roadbase backfill.** This material shall be Class 6 aggregate base course as specified by the State of Colorado Department of Highways; and shall meet the following gradation:

Sieve Size	Total Percent Passing by Weight
3/4-inch	100
No. 4	30 - 65
No. 8	20 - 55
No. 200	3 - 12

- (3) **Squeegee Sand.** This material shall be clean, well graded and conform to the following limits when tested by means of laboratory sieves:

Sieve Size	Total Percent Passing by Weight
3/8-inch	100
No. 4	20-80
No. 8	10-25
No. 16	0-10
No. 200	0-2

With this material, depending on the nature of the surrounding soils and ground water conditions, the District may require a geotextile envelope around the backfill zone and/or the installation of clay dams in the trench. Clay dams, if required, will typically be placed at about one per 400 feet of sewer.

- (4) Granular bedding or granular backfill material. This material shall be imported crushed rock or angular surfaced gravel and meet the following gradation (ASTM D448, No. 67):

Sieve Size	Total Percent Passing by Weight
1-inch	100
3/4-inch	90-100
3/8-inch	20-55
No. 4	0-10
No. 8	0-5

With this material, depending on the nature of the surrounding soils and ground water conditions, the District may require a geotextile envelope around the backfill zone and/or the installation of clay dams in the trench. Clay dams, if required, will typically be placed at about one per 400 feet of sewer.

- (5) "7/8-inch Aggregate":

Sieve Size	Total Percent Passing by Weight
12-inch	100
1-inch	90-100
3/4-inch	60-80
3/8-inch	0-15
No. 4	0-5

With this material, depending on the nature of the surrounding soils and ground water conditions, the District may require a geotextile envelope around the backfill zone and/or the installation of clay dams in the trench. Clay dams, if required, will typically be placed at about one per 400 feet of sewer.

- (6) **Select material.** Select material shall not be permitted unless authorized by the Engineer. This material shall consist of suitable material screened from the excavated earth having no rocks or stones greater in size than 2 inches for DIP or RCP and 3/4-inch for all other pipe.
- (7) **Trench stabilization material.** This material shall be a 3/4 to 12-inch uniformly-graded, crushed rock or concrete aggregate.
- (8) **Backfill material.** Backfill material shall consist of suitable material from the excavated earth, meeting all the requirements of the Specifications.

No boulders over 6 inches in any dimension shall be allowed in the top 12 inches of the trench. All boulders shall be carefully placed so that no damage will be done to the pipeline. No backfill material shall have boulders larger than 24 inches in any dimension. Boulders larger than 8 inches in any dimension shall be carefully lowered into the trench until the backfill is 4 feet over the top of the pipe.

c. **Bedding and Backfill Installation:**

- (1) **General.** Unless accurate results cannot be obtained, the compaction requirements shall conform to maximum dry density according to ASTM D698, Moisture-Density Relations of Soils (Standard Proctor). When the ASTM D698 test is not applicable, the percentage compaction requirements shall conform to ASTM D2049, Test for Relative Density of Cohesionless Soils.

When required by the Engineer, the Developer shall excavate backfilled trenches for the purpose of performing compaction tests at locations and depths required by the Engineer. The Developer shall be responsible for reinstalling and compacting the test excavations at no additional cost to the District.

- (2) **Bedding zone installation.** Bedding material shall consist of the material on which the pipe is placed in accordance with the Pipe Trench Details. Bedding material shall be placed to the required elevation of the pipe invert. Tamping equipment shall be used to thoroughly tamp the bedding material to a minimum of 95 percent maximum dry density (Standard Proctor) or to



75 percent relative density. The moisture content of the material shall be within 2 percent of optimum.

- (3) Pipe zone installation. After bedding material has been placed and approved and after the pipe has been installed and approved, the pipe zone backfill shall be installed to an elevation shown on the details on the drawings.

The backfill material shall be as specified on the details and shall be placed and compacted in distinct, separate lifts not to exceed 6 inches of loose depth; except that the first loose lift shall not be higher than the pipe centerline (springline). If select backfill materials are permitted in this zone but acceptable select backfill material (suitable for placement within 12 inches of the pipe barrel) is not available at any particular location, the Developer shall use imported granular backfill material. Compaction shall meet the requirements of "Bedding Zone Installation," utilizing T-bars or mechanical tamping equipment.

- (4) Backfill zone installation. Unless otherwise provided in the Special Construction Provisions, the following method of installation shall apply. After the pipe zone backfill has been placed and approved, the trench shall be backfilled. All backfill above the pipe zone backfill shall be carefully placed in the trench in lifts no greater than 2 feet. Each lift shall be compacted by mechanical equipment to 90 percent of maximum laboratory dry density (Standard Proctor). After the trench is backfilled to the ground surface level, a loaded dump truck or loader placed in the trench line shall compact the backfill by its wheel load. No less than two passes shall be made. If the backfill is depressed below the finished grade elevation, the depressed area shall be refilled and compacted. The backfill shall be mounded higher than the adjacent ground to allow for settlement.

- (5) Backfill zone installation in roads and streets. Beneath all traveled ways in roads and streets, highway shoulders and within 15 feet of pavement in State Highway Department rights-of-way (unless otherwise specified on the plans) backfill shall be carefully placed and compacted up to the limit of base course material or to gravel. Compaction shall be by mechanical tamping in 8-inch maximum loose lifts using mechanical or hand tampers, weighing not less than 20 pounds, or vibratory rollers. All other means must be approved in writing by the Engineer. All backfill shall be compacted to 95% of

maximum laboratory dry density (Standard Proctor) or 70 percent relative density. The material shall be within 2.0 percent of optimum moisture content. If backfill zone falls in a paved road where the pavement is 5 years old or less, flow fill or an approved equal will be required.

The Developer may request approval of alternate means of compaction. Such request must be submitted to the Engineer in writing. Approval of the compaction method will be made by the Engineer only in writing. Use of specified or approved compaction methods does not relieve the Developer from providing a completed project meeting the intent of this Specification.

- d. **Maintenance of Backfill.** All backfill shall be maintained in a satisfactory condition and all places showing signs of settlement shall be filled and maintained for a period of two years following the date of final acceptance of all work performed. When the Developer discovers or is notified by the Engineer or the District that any backfill is not in compliance with these requirements, the Developer shall correct such condition at once. Any utilities and road surfacing damaged by such settlement shall be repaired by the Developer to the satisfaction of the District and Engineer. In addition, the Developer shall be responsible for the cost to the District of all claims for damages filed with the Court and actions brought against the said District for, and on account of, such damage.
  
- e. **Erosion Control.** Erosion control is the responsibility of the contractor and shall conform to guidelines as recommended by the Grand County Dept. of Planning and Zoning. Re-vegetation of all disturbed areas is required upon completion of all projects in the Winter Park Ranch District.

## **2.7 FLUSHING, TESTING AND ACCEPTANCE**

### **2.71 Sanitary Sewer Line Testing**

The following testing procedures are intended to determine if the sanitary sewer line meets the District's minimum quality standards. Alternative procedures meeting or exceeding the intent of these procedures, as determined by the District's Engineer, may be acceptable. In any case, however, proposed alternative testing procedures must be included in the design plans and specifications.

The Contractor shall notify the District's Inspector - no less than 48 hours prior to the desired test time.

The District's Inspector shall witness all tests and verify the accuracy and acceptability of the equipment utilized. The District's Engineer will inform the Contractor regarding acceptable methods of repair in the event that one or more sections fail to pass any test.

#### **2.71a Pipeline Flushing**

The Contractor shall flush the pipelines, as the work progresses by means that are in accordance with good practice, to insure that earth, sand, rocks or other foreign materials are removed from the interior of the pipeline. Upon completion of construction, the pipeline shall be jetted and then televised and the District shall be given a copy of the DVD, describing the pipeline and any problems or issues with the pipeline and/or manhole.

#### **2.71b Alignment and Grade**

Sewer pipelines will be checked by the District's Inspector to determine whether any displacement of the pipe has occurred after the trench has been bedded. The test will be as follows:

A light will be flashed between manholes, or if the manholes have not as yet been constructed, between the locations of the manholes, by means of a flashlight or by reflecting sunlight with a mirror. If the illuminated interior of the pipelines shows poor alignment, displaced pipe, earth, or other debris in the pipe, or any other kinds of defects, the defects, determined by the District's Inspector, shall be remedied by the Contractor. The test will be repeated following completion of backfilling and any poor alignment, displaced pipe, or other defects, determined by the District's Inspector, shall be corrected at no cost to the District.

#### **2.71c Leakage Testing by Exfiltration**

Tests for watertightness shall be made by the Contractor in the presence of the District's Inspector. The Contractor shall provide assistance to the District's Inspector in development of a detailed record of the testing program. The sewer and connections shall not leak in excess of the following rate for a 24-hour test period:

MAXIMUM ALLOWABLE SEWER LEAKAGE	
Pipe Size Inches	Leakage Gal/Foot/24 Hours
18	0.68
15	0.57
12	0.45
10	0.38
8	0.30
6	0.23

Each reach of pipeline between manholes shall be tested individually. Any individual reach that leaks in excess of the amount allowed in the previous paragraph shall be considered as failing, and shall be repaired and retested.

At the discretion of the District's Inspector, the time for leakage rate test may be shortened to four (4) hours.

The tests and measurement of infiltration or exfiltration shall be conducted in a manner as approved by the District's Inspector. The minimum head for the exfiltration tests shall be 2 feet above the top of the pipe at its highest point in the test section. Sections shall be bulk-headed so that during any test the head on the sewer at its lowest elevation will not be more than 10'. This restriction does not apply to ductile-iron pipe.

The Contractor shall repair the sewer in a manner that is satisfactory to the District's Inspector and re-test until satisfactory tightness is obtained.

**2.71d Leakage Testing by Infiltration**

Infiltration tests will be used if the groundwater table is likely to be 1 foot or more above the invert of the finished sewer. Otherwise, exfiltration tests will be used. The allowable leakage rates are as tabulated for section 2.71c, Leakage Testing by Exfiltration.

**2.71e Low-Pressure Air Test**

At the option of the Contractor, low-pressure air testing of the installed sewer pipe may be used instead of the leakage exfiltration test.

The following criteria and procedure shall be utilized, unless otherwise approved by the District's Inspector.

- (1) **Plug Restraint.** It is extremely important and essential that all plugs be installed and braced in such a way that blowouts are prevented. It is recommended that every plug be positively braced and that no one be allowed in the manhole adjoining a line being tested so long as pressure is maintained in the line.
- (2) **Relief Valve.** All pressurizing equipment used for low-pressure air testing shall include a regulator or relief valve set no higher than 9 psig to avoid over-pressurizing and displacing temporary or permanent plugs. As an added safety precaution, the pressure in the test section should be continuously monitored to make certain that it does not at any time exceed 9 psig.
- (3) **Plug Design.** Either mechanical or pneumatic plugs may be used. All plugs shall be designed to resist internal testing pressures without the aid of external bracing or blocking. However, the Contractor should internally restrain or externally brace the plugs to the manhole wall as an added safety precaution throughout the test.
- (4) **Singular Control Panel.** To facilitate test verification by the inspecting Engineer, all air used shall pass through a single, above ground control panel.
- (5) **Equipment Controls.** The above ground air control equipment shall include a shut-off valve, pressure regulating valve, pressure relief valve, input pressure gauge, and a continuous monitoring pressure gauge having a pressure range from 0 to at least 10 psi. The continuous monitoring gauge shall be no less than 4 inches in diameter with minimum divisions of 0.10 psi and an accuracy of  $\pm 0.04$  psi.
- (6) **Separate Hoses.** Two separate hoses shall be used to: (1) connect the control panel to the sealed line for introducing low-pressure air, and (2) a separate hose connection for constant monitoring of air pressure build-up in the line. This requirement greatly diminishes any chance for over-pressurizing the line.
- (7) **Pneumatic Plugs.** If pneumatic plugs are utilized, a separate hose shall also be required to inflate the pneumatic plugs from the above ground control panel.

(8) **Laterals, Stubs, and Fittings.** During sewer construction all service laterals, stubs, and fittings into the sewer test section shall be properly capped or plugged so as not to allow air loss that could cause an erroneous air test result. It may be necessary and is always advisable to restrain gasketed caps, plugs, or short pipe lengths with bracing stakes, clamps and tierods, or wire harnesses over the pipe bells.

(9) **Plug Installation and Testing.** After manholes have been tested for alignment and grade, and a manhole-to-manhole reach of pipe has been backfilled to final grade and prepared for testing, the plugs shall be placed in the line at both manholes and secured. It is necessary to have well cleaned sewer lines to assure proper sealing of the plugs.

It is advisable to seal test all plugs before use. Seal testing may be accomplished by laying one length of pipe on the ground and sealing it at both ends with the plugs to be checked. The sealed pipe should be pressurized to 9 psig. The plugs shall hold against this pressure without bracing and without any movement of the plugs out of the pipe. No persons shall be allowed in the alignment of the pipe during plug testing.

The upstream end of the line shall be plugged first to prevent any upstream water from collecting in the test line.

(10) **Line Pressurization.** Low pressure air shall be slowly introduced into the sealed line until the internal air pressure reaches 4.0 psig.

(11) **Pressure Stabilization.** After a constant pressure of 4.0 psig is reached, the air supply shall be throttled to maintain that internal pressure for at least 2 minutes. This time permits the temperature of the entering air to equalize with the temperature of the pipe wall.

(12) **Timing Pressure Loss.** When temperatures have been equalized and the pressure stabilized at 4.0 psig, the air hose from the control panel to the air supply shall be shut off or disconnected. The continuous monitoring pressure gauge shall then be observed while the pressure is decreased to no less than 3.5 psig. The timing pressure loss test shall then commence at a pressure reading of 3.5 psig, or any convenient observed pressure reading between 3.5 psig and 4.0 psig. (Except as adjusted for groundwater as follows.)

- (13) **Air Pressure Adjustment.** An air pressure correction, which must be added to the 3.5 psig normal test starting pressure, shall be calculated by dividing the average vertical height, in feet of groundwater above the invert of the sewer pipe to be tested, by 2.31. The result gives the air pressure correction in pounds per square inch to be added. (For example, if the average vertical height of groundwater above the pipe invert is 2.8 feet, the additional air pressure above the pipe invert is 2.8 divided by 2.31 or 1.2 psig. This would require a minimum starting pressure of 3.5 plus 1.2 or 4.7 psig). The allowable pressure drop of 1.0 psig and the timing in Table I are not affected and shall remain the same. In no case however should the starting test pressure exceed 9.0 psig.
- (14) **Determination of Line Acceptance.** If the time shown in Table I for the designated pipe size and length, elapses before the air pressure drops 1.0 psig, the section undergoing test shall have passed.

TABLE 1  
SPECIFICATION TIME REQUIRED FOR A 1.0 PSIG PRESSURE DROP  
FOR SIZE AND LENGTH OF PIPE INDICATED FOR Q = 0.0015

1 Pipe Diameter (in.)	2 Minimum Time (min: sec)	3 Length for Minimum Time (ft)	4 Time for Longer Length (sec)	Specification Time for Length (L) shown								
				100 ft	150 ft	200 ft	250 ft	300 ft	350 ft	400 ft	450 ft	
4	3:46	597	.380 L	3:46	3:46	3:46	3:46	3:46	3:46	3:46	3:46	3:46
6	5:40	398	.854 L	5:40	5:40	5:40	5:40	5:40	5:40	5:40	5:42	6:24
8	7:34	298	1.520 L	7:34	7:34	7:34	7:34	7:36	8:52	10:08	11:24	
10	9:26	239	2.374 L	9:26	9:26	9:26	9:53	11:52	13:51	15:49	17:48	
12	11:20	199	3.418 L	11:20	11:20	11:24	14:15	17:05	19:56	22:47	25:38	
15	14:10	159	5.342 L	14:10	14:10	17:48	22:15	26:42	31:09	35:36	40:04	
18	17:00	133	7.692 L	17:00	19:13	25:38	32:03	38:27	44:52	51:16	57:41	

**2.71f Deflection**

All PVC sewer pipelines shall be tested for vertical deflection after placement and compaction of backfill unless testing is specifically exempted by the District=s Inspector. Method of testing shall be by deflectometer of the rigid GO/No-GO type device and/or laser technology. Alternative methods will be permitted only by written permission of the District=s Inspector. Maximum allowable deflection shall be five (5) percent of the pipe diameter. Any and all pipe with vertical

deflection greater than the allowable shall be excavated, removed from the pipeline, replaced, backfilled and compacted as specified and retested.

The District reserves the right to direct the Developer to retest sewer lines after 20 to 22 months of service (or before paving), if the District has concerns about the condition of certain sections of pipe. Sections would be selected for retesting based on the results of the initial tests, the outcome of the television inspection (per Section 2.73), depth of cover, or other technical factors. The Developer shall perform such retesting at no cost to the District.

## **2.72 Testing Manholes**

During the construction of the manholes, the Contractor shall, in accordance with good practice, insure that no earth, sand, rocks or other foreign material exists on the joint surface during assembly of the sections. The District's Inspector shall check each manhole to determine whether the manhole fulfills the requirements of the Drawings and District's Standards.

### **2.72a Visual Examination**

The District's Inspector shall visually check each manhole, both exterior and interior, for flaws, cracks, holes, or other inadequacies which might affect the operation or watertight integrity of the manhole. Should any inadequacies be found, the Contractor shall make any repairs deemed necessary by the District's Inspector.

### **2.72b Leakage Test**

All manholes shall be tested for leakage and all tests shall be witnessed by the District's Inspector. The leakage test shall be conducted prior to backfilling around the manhole and shall be carried out in the following manner:

- (1) All lines leading into or out of the manhole shall be tightly plugged.
- (2) The manhole shall be filled with water to a level at least 2 inches above the uppermost step. The water shall be allowed to stand for two hours to allow for normal water absorption into the manhole material. At the end of the two-hour stabilization period, if the water level in the manhole has dropped below the top step, additional water will be added to bring the level above the step as before. Any visible external leakage or drop in water level noted within the one-hour test period shall constitute failure and the Contractor shall repair or replace the defective work and retest.



- (3) Vacuum Testing. At the option of the Contractor, vacuum testing of the installed manholes may be used instead of the leakage test. All pipes entering and exiting the manhole shall be temporarily plugged, taking care to securely brace the pipes and plugs to prevent them from being drawn into the manhole.

The test head shall be placed at the top of the manhole and the seal inflated in accordance with the manufacturer's recommendations.

A vacuum of 10-inches of mercury shall be drawn on the manhole, the valve on the vacuum line of the test head shall be closed, and the vacuum pump shut-off. The time shall be measured for the vacuum to drop to 9-inches of mercury.

The manhole will be declared unacceptable if the time to drop from 10-inches of mercury to 9-inches of mercury is less than 60 seconds. This test interval is valid for 48" MH of up to 24' depth, 60" MH up to 18' deep and 72" MH up to 14' deep. The District Engineer will establish test intervals for other situations on a case-by-case basis.

### **2.73 Deferred Television Inspection**

The Developer shall perform a television inspection of each segment of the sewer line and record this inspection on a VHS tape or DVD, which is to be turned over to the District. The format for labeling and stationing of this record is to be approved by the District prior to performing the TV inspection. The Developer is to provide one week prior notice of this TV inspection, so that a representative from the District may be present to observe the inspection in progress. This inspection is to be performed no earlier than 20 months after preliminary acceptance of the sewer construction by the District. The tape is to be submitted to the District no later than 22 months after the date of preliminary acceptance (or before paving). This work is to be performed at no cost to the District.

The District will use this record as a basis to direct the Developer to perform additional deflection tests or provide Warranty work under the terms of the Two-Year Warranty, if out-of-spec situations are observed.

## **2.8 CHECKLIST**

Checklist for Preliminary Acceptance of District Facilities. To be completed after construction and prior to any service connections.

- 2.81 Construction of all District facilities completed to District Standards and to the approved plans.
- 2.82 All facilities tested to District Standards and accepted by the District's Engineer. (Furnish copies of soils compaction and materials tests).
- 2.83 Permanent survey monuments set at the corners of all easements.
- 2.84 Record drawings meeting District Standards and sealed by a registered Professional Engineer, in the form of blueline drawings (set of three (3)), one mylar transparency, and three (3) DVD's shall have been submitted to the District. All survey control shall use the geodetic values for control established for the District's G.P.S. mapping.
- 2.85 Furnish a summary of total construction costs (including design costs) of all applicable sewer drainage facilities (include only facilities to be deeded to the District).
- 2.86 Warranty Deed for all facilities to be owned by the District.
- 2.87 Two year Maintenance Bond to begin after the date of preliminary acceptance, except that if deficiencies are identified and repaired, a new two-year maintenance bond for the repaired Work is to begin starting on the date of preliminary acceptance of the repaired Work.
- 2.88 Payment of all fees and confirmation from District's Attorney that the applicant for dedication of the facilities is not in default under any agreements with the District and/or Grand County and/or any appropriate municipality.
- 2.89 The District shall be provided any and all easements necessary to maintain the infrastructure being accepted by the District.
- 2.90 All punch list items arising during the two (2) year warranty shall be completed.

**SECTION 3  
SEWER SERVICE LINE STANDARDS**

**3.1 GENERAL**

No service line may be constructed without prior approval from the District. The Applicants must provide adequate information describing the nature of the building or development to be connected, the proposed service line size, and the proposed connection point of the service line to the main. A site plan, showing the location of the proposed service line relative to other utilities on and adjacent to the property must be presented. The drawing must show the location of buildings served and parts of the site that are to be paved or otherwise intended to be kept clear of snow, and must also show service line slope and depth of cover over the service line.

The sizing of sewer service lines shall be the responsibility of the Applicant. When requested by the District, the Applicant shall, at their expense, furnish data, plans, calculations, or other information as required for the evaluation of the service size. Service lines are the responsibility of the Developer, who is responsible for design and construction and the costs thereof and for payment of actual costs of review and inspection provided by the District.

**Ownership:** The service line, from the main (saddle tap) to the point of connection to the building(s) is the property of the owner of the lot served. Repairs are the responsibility of the property owner, who is responsible for obtaining the necessary permits for the work.

All sanitary sewer service lines are to be constructed in accordance with applicable codes, generally accepted good construction practices, and the minimum standards and criteria contained in this document. The details are provided for standardization purposes only, and represent minimum design standards which may require upgrading for specific applications.

**3.2 SANITARY SEWER SERVICE CONNECTIONS**

**3.21 Sizing/Capacity**

The size and slope of the building service sewer shall be subject to the approval of the District, but in no event shall the diameter be less than 4". Minimum grade and slopes shall be as follows:

4"	..... 2.0% Normal; 1.0% Minimum
6"	..... 1.00%
8"	..... 0.60%

### **3.22 Service Connection**

No connection between the sewer system of the District and the sewer facilities of the owner may be made except in a public street adequate to accommodate sewer facilities or in a similar place to which the District has as free a right of access as it would have in a public street.

Sump pumps and garage floor drains are prohibited from being connected to the sewer service line. Exceptions will be made for garage floor drains with a sand/oil separator which has been approved by the District.

Where parallel or approximately parallel to a structural wall, the service shall be at least 5 ft. from the wall. Penetrations through structures shall be approximately at right angles and shall provide flexibility such that the service will not be damaged by settlement of the structures.

Water and sewer service lines shall have 10 feet minimum of horizontal separation. Where this separation is impractical, the District may permit other separation requirements, in accordance with applicable standards. If a sewer service line passes over a water main or service, or if it lies within 10 feet of the water main or service, the sewer service is to be modified to have no bell within 10 ft as per construction per Drawing A.8.

The minimum cover shall be 7 feet from top of sewer service line to finished grade. A minimum of 5 feet of cover will be allowed for short distances, if at least 2 inches of an approved pipeline insulation is provided. See Drawing A.6 for detail. If the service line passes beneath a paved area (or other areas likely to be kept clear of snow) within the property line of the property served, the line should be insulated as deemed prudent.

The applicant for a building service sewer shall notify the District at least 24 hours before service line is ready for connection to the public sewer, and the connection to said public sewer shall not be made until after inspection and approval by the District. The service line shall meet the requirements of the Uniform Plumbing Code. The connection to the sewer shall be made in the presence of and approved by the District's Inspector. The trench of each sewer service line must be open (not backfilled) from the building to the tap, to allow inspection by the District prior to backfilling.

If practicable, pre-installed wye fittings shall be used for service connections; otherwise the connection of the building service sewer to the public sewer shall be made as follows: A saddle tee shall be used to connect 4" or 6" sewer service lines to 8" to 15" sewer mains. No saddle wyes are allowed. The service line connection shall conform to the Drawing B.1 "Sewer Service Connection Detail. To simplify later location of service connection points in plastic pipe, bury 1-2 pound piece of magnetic material within 12" of the joint and approx. 12" above.

Each service line is to have a 4" cleanout installed within 20' of the building served, per Drawing B.2, Service Line Cleanout Detail. Cleanouts are required for any significant change in service line direction and at intervals of no greater than 90'.

### **3.23 Pipeline Materials**

Sewer service pipe shall be PVC, with a thickness not less than SDR 35. Sanitary Sewer Service Pipe shall be green or other acceptable color (no white pipe -- white PVC is reserved for other applications).

### **3.24 Service Line Installation**

The line shall be water tight and on a constant grade in a straight line, and not closer than 5 feet from any bearing wall.

### **3.3 Documentation**

The Applicant shall submit a dimensioned sketch to the District, showing the location of the point of connection, relative to visible and reasonably permanent surface features that is acceptable to the District.

These designs, plans, and documents are reviewed for concept and general conformance to the Districts minimum standards only, and the primary responsibility for design adequacy is to remain with the Engineer of record. This review does not imply responsibility by either the Winter Park Ranch Water and Sanitation District or the District's Water System Engineer for completeness, accuracy or correctness of calculations. The review does not imply that quantities of items indicated on the Plans are the final quantities required. The review shall not be construed for any reason as acceptance of financial responsibility by the District for additional items and additional quantities of items shown that may be required during the construction phase.

Approved for construction within one year of the earliest of these dates:

By \_\_\_\_\_ Date \_\_\_\_\_  
District Water System Engineer

By \_\_\_\_\_ Date \_\_\_\_\_  
Winter Park Ranch W. & S. D.

## Standard Approval Block

THESE DETAILS ARE PROVIDED FOR STANDARDIZATION PURPOSES ONLY. THIS DETAIL REPRESENTS MINIMUM DESIGN STANDARDS WHICH MAY REQUIRE UPGRADING FOR SPECIFIC APPLICATIONS. REFER TO W.P.R.-W & S DIST UTILITY CONSTRUCTION STANDARDS AND MINIMUM DESIGN CRITERIA FOR SPECIFIC MATERIAL AND INSTALLATION REQUIREMENTS.

Winter Park Ranch Water and Sanitation District - Sewer System  
Standard Details Dwg. A.1 JULY 2008

Modified July 2008 by Gary M. Cooper, P.E.

- A LOCATE WATER LINE BENDS.
- B LOCATE WATER LINE TEES & CROSSES.
- C LOCATE ALL VALVES, SERVICES & MAINS.
- D LOCATE ANY SPECIALTY ITEMS. (E.G. FIRE HYDRANTS, METER VAULTS, ARV VAULTS, PRV VAULTS, COUPLINGS, ETC...)
- E NOTE DISTANCES TO EDGE OF PAVEMENT AND TO R.O.W. OR EASEMENTS.
- F LOCATE ALL SERVICE TAPS AND LINES.
- G NOTE ANY KNOWN R.O.W. AND EASEMENT INFORMATION.
- H NOTE FINAL INVERT ELEVATIONS W/ BENCHMARK ELEVATION REFERENCED.
- J NOTE LENGTH, SIZE MATERIAL AND SLOPE OF LINE AS INSTALLED.
- K NOTE DISTANCES BETWEEN UNDERGROUND UTILITIES.
- L NOTE PERMANENT EASEMENT MONUMENTS AND PROPERTY CORNERS (PC) WHERE USED FOR TIES.
- M NOTE SERVICE STREET ADDRESSES.

DRAFT "AS-RECORDED" DRAWINGS TO SCALE

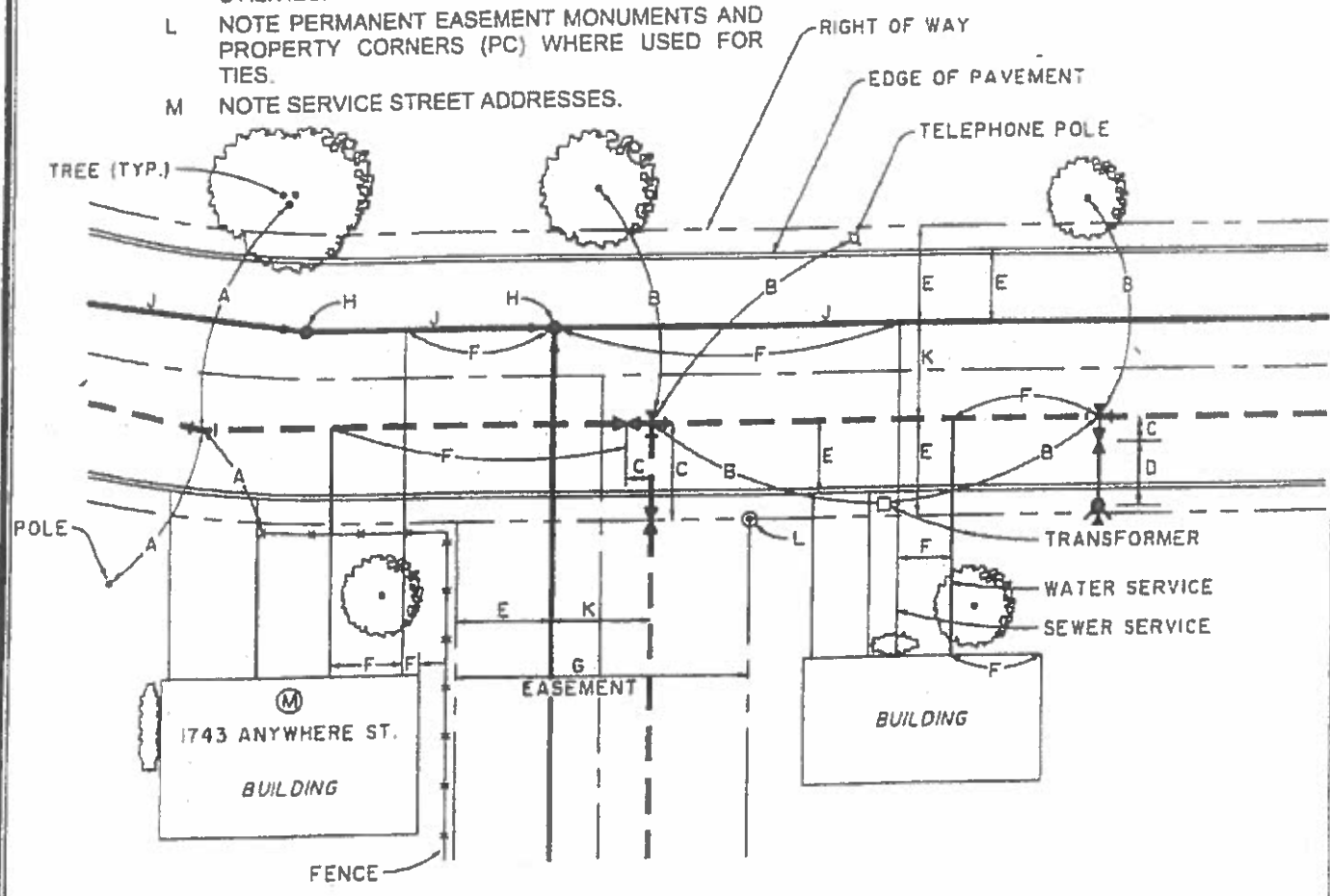

## Typical "As Recorded" Drawing Information

THESE DETAILS ARE PROVIDED FOR STANDARDIZATION PURPOSES ONLY. THIS DETAIL REPRESENTS MINIMUM DESIGN STANDARDS WHICH MAY REQUIRE UPGRADING FOR SPECIFIC APPLICATIONS. REFER TO DISTRICT'S WATER UTILITY CONSTRUCTION STANDARDS AND MINIMUM DESIGN CRITERIA FOR SPECIFIC MATERIAL AND INSTALLATION REQUIREMENTS.

Winter Park Ranch Water & Sanitation District  
 Standard Details Dwg. A.2 JULY 2008

Modified July 2008 by Gary M. Cooper, P.E.

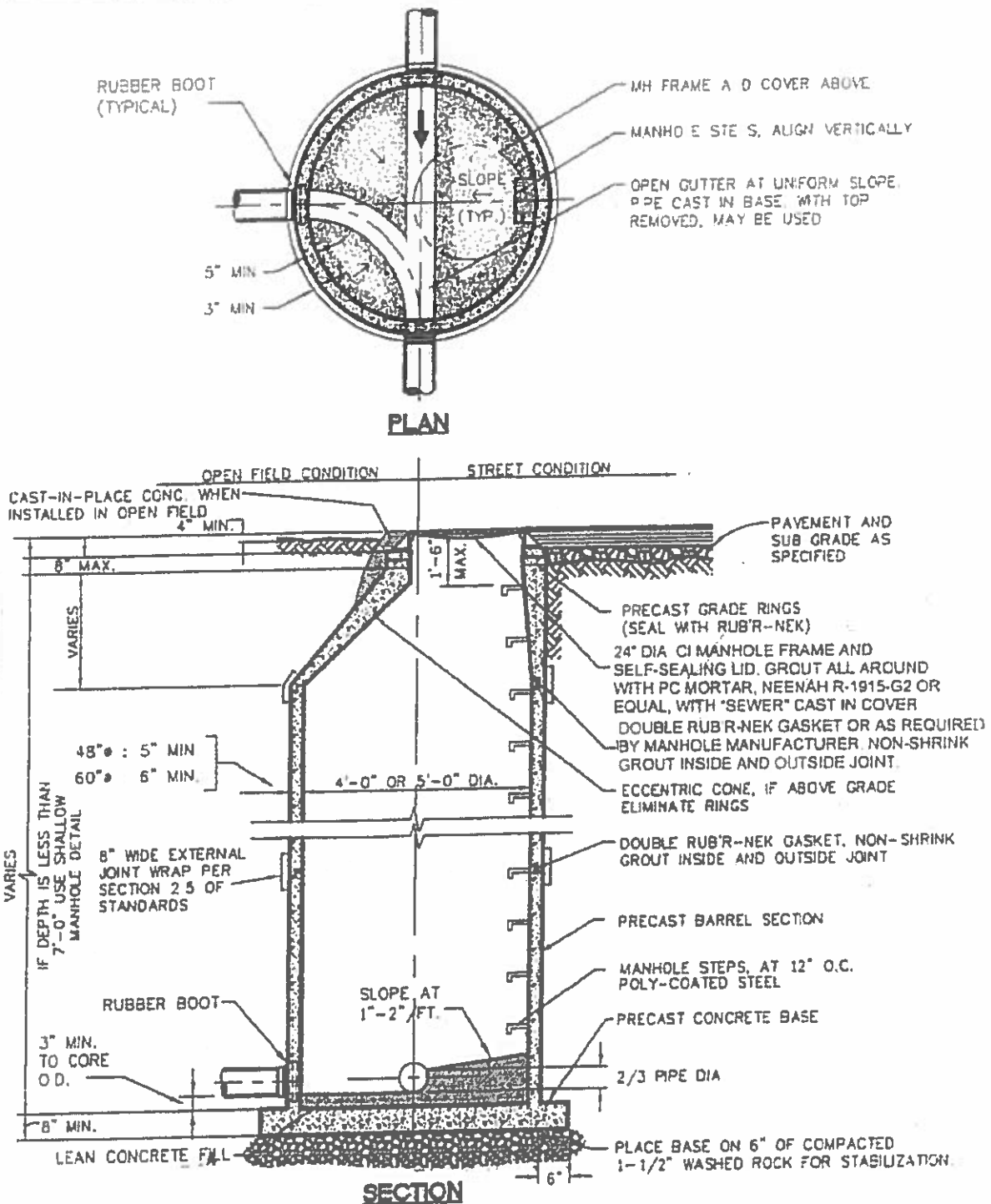

## Standard Precast Concrete Manhole

THESE DETAILS ARE PROVIDED FOR STANDARDIZATION PURPOSES ONLY. THIS DETAIL PRESENTS MINIMUM DESIGN STANDARDS WHICH MAY REQUIRE UPGRADING FOR SPECIFIC APPLICATIONS. REFER TO DISTRICT'S WATER UTILITY CONSTRUCTION STANDARDS AND MINIMUM DESIGN CRITERIA FOR SPECIFIC MATERIAL AND INSTALLATION REQUIREMENTS.

Winter Park Ranch Water & Sanitation District  
Standard Details Dwg. A.3 JULY 2008

Modified July 2008 by Gary M. Cooper, P.E.



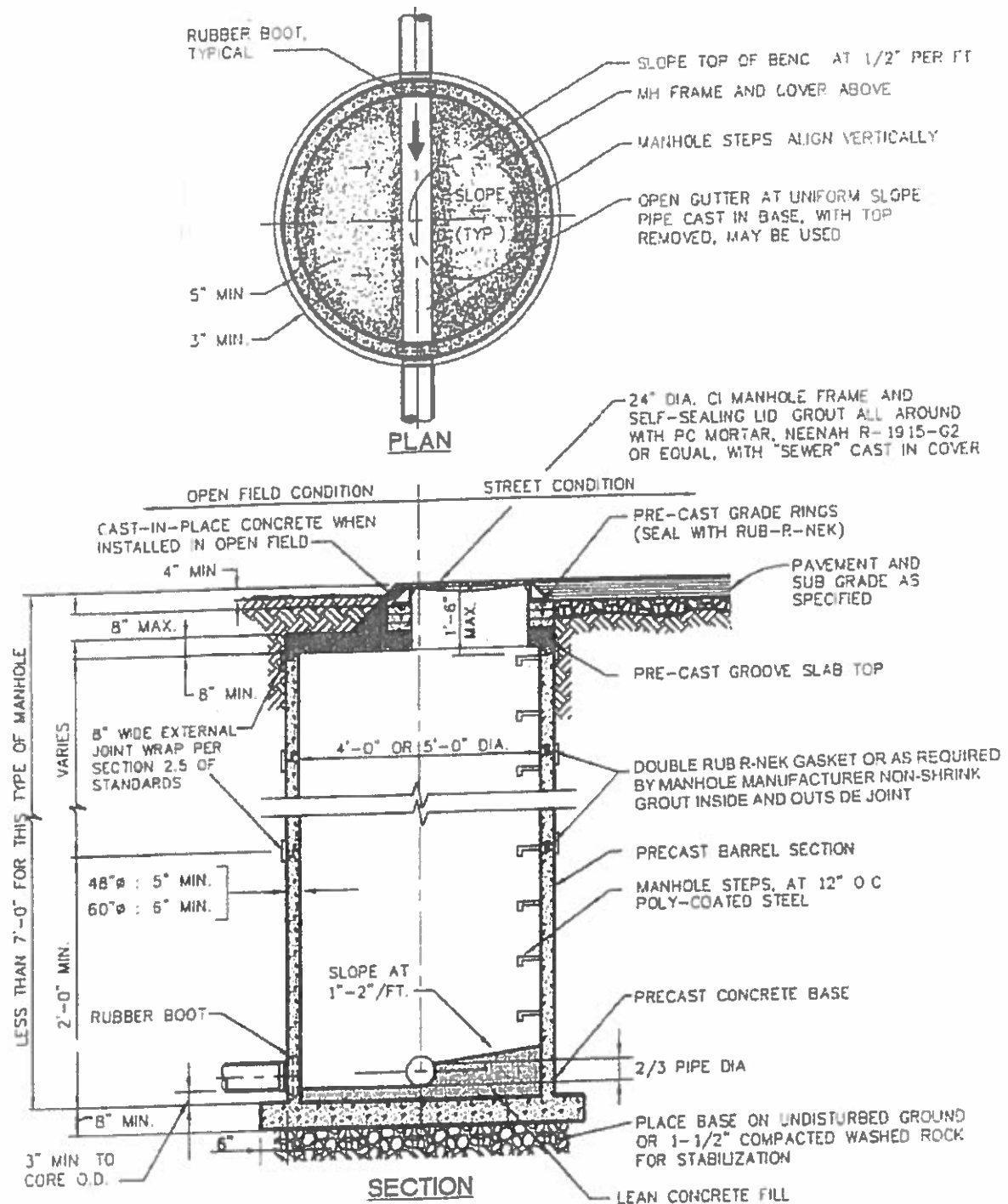

## Shallow Precast Concrete Manhole

THESE DETAILS ARE PROVIDED FOR STANDARDIZATION PURPOSES ONLY THIS DETAIL REPRESENTS MINIMUM DESIGN STANDARDS WHICH MAY REQUIRE UPGRADING FOR SPECIFIC APPLICATIONS REFER TO DISTRICT'S WATER UTILITY CONSTRUCTION STANDARDS AND MINIMUM DESIGN CRITERIA FOR SPECIFIC MATERIAL AND INSTALLATION REQUIREMENTS

Winter Park Ranch Water & Sanitation District  
Standard Details Dwg. A.4 JULY 2008

Modified July 2008 by Gary M. Cooper, P.E.

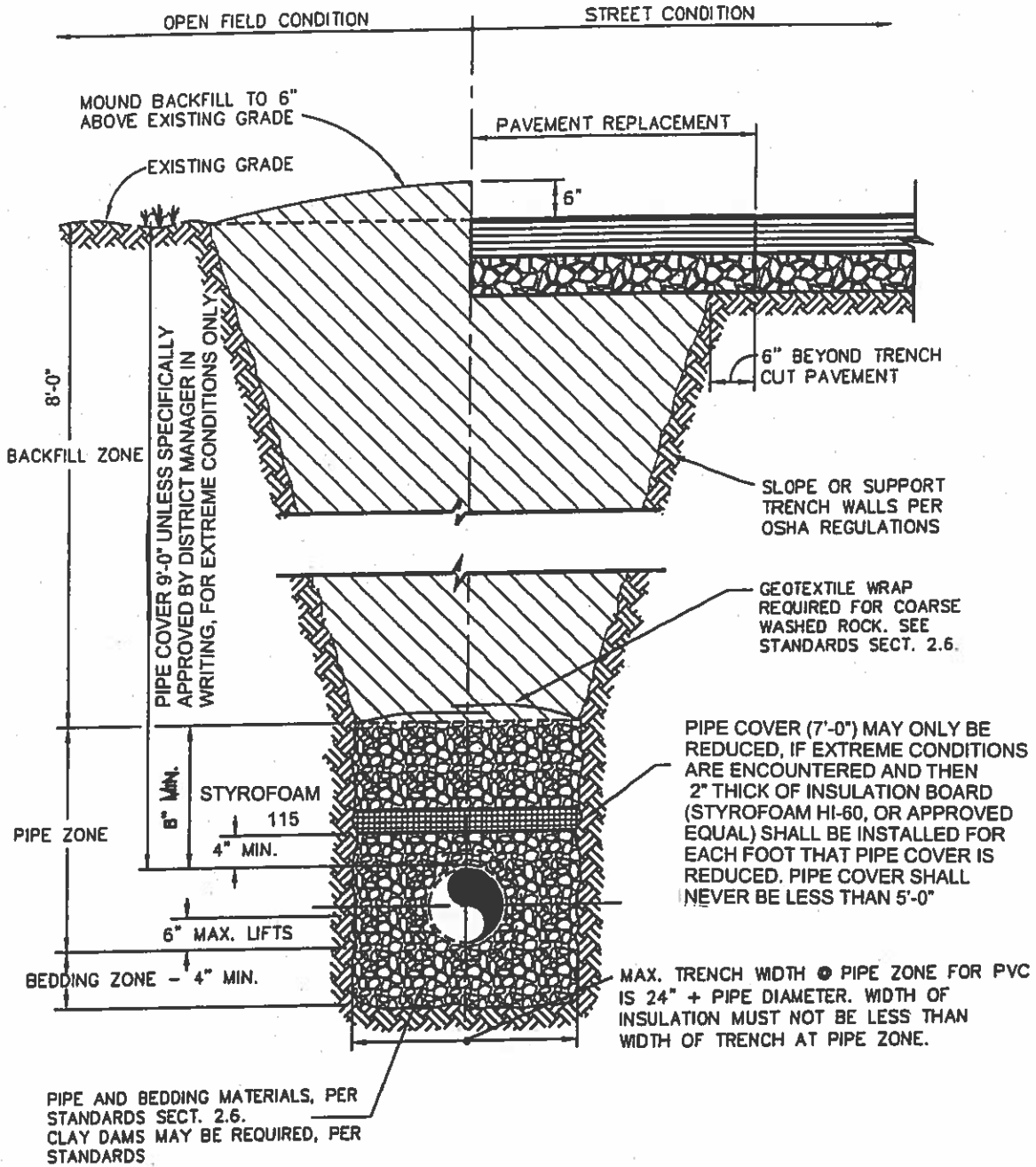

## Sewer Main Bedding & Backfill Detail

THESE DETAILS ARE PROVIDED FOR STANDARDIZATION PURPOSES ONLY, THIS DETAIL REPRESENTS MINIMUM DESIGN STANDARDS WHICH MAY REQUIRE UPGRADING FOR SPECIFIC APPLICATIONS. REFER TO DISTRICT'S UTILITY CONSTRUCTION STANDARDS AND MINIMUM DESIGN CRITERIA FOR SPECIFIC MATERIAL AND INSTALLATION REQUIREMENTS.

Winter Park Ranch Water & Sanitation District  
 Standard Details Dwg. A.6 JUNE 2008

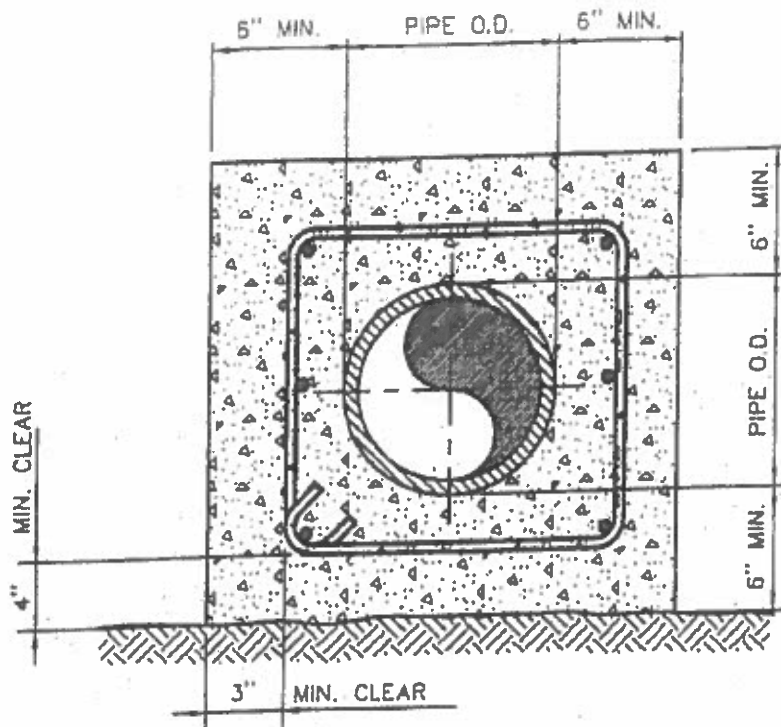

PIPE ENCASEMENT DETAIL

4-NO. 5 BARS CONTINUOUS FOR  
8" PIPE AND 6-NO. 5 BARS  
CONTINUOUS FOR 10" OR LARGER.

NO. 4 TIES AT 18" O.C.

## Pipe Encasement Detail - Sewer

THESE DETAILS ARE PROVIDED FOR STANDARDIZATION PURPOSES ONLY. THIS DETAIL REPRESENTS MINIMUM DESIGN STANDARDS WHICH MAY REQUIRE UPGRADING FOR SPECIFIC APPLICATIONS. REFER TO DISTRICT'S WATER UTILITY CONSTRUCTION STANDARDS AND MINIMUM DESIGN CRITERIA FOR SPECIFIC MATERIAL AND INSTALLATION REQUIREMENTS.

Winter Park Ranch Water & Sanitation District  
Standard Details Dwg. A.7 JULY 2008

Modified July 2008 by Gary M. Cooper, P.E.

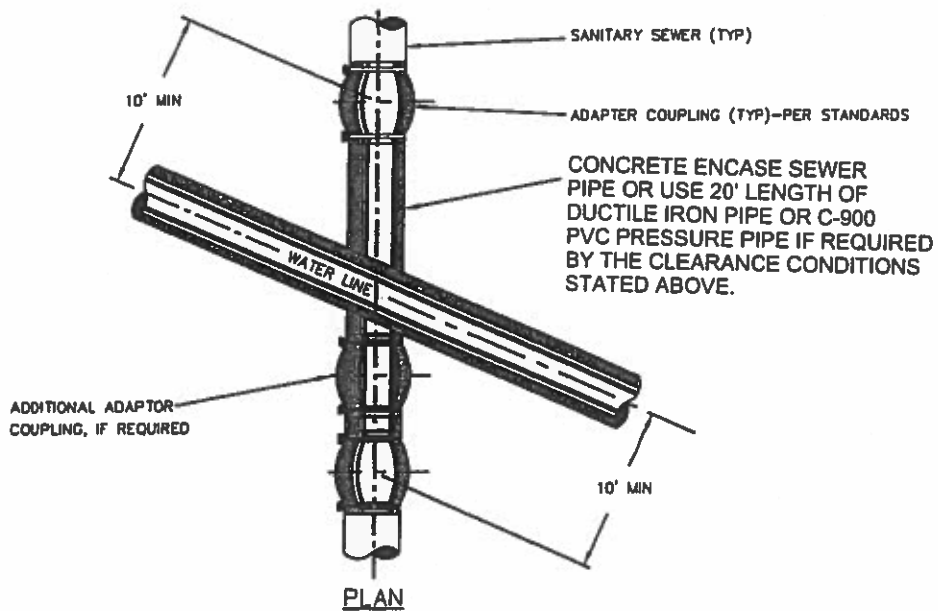
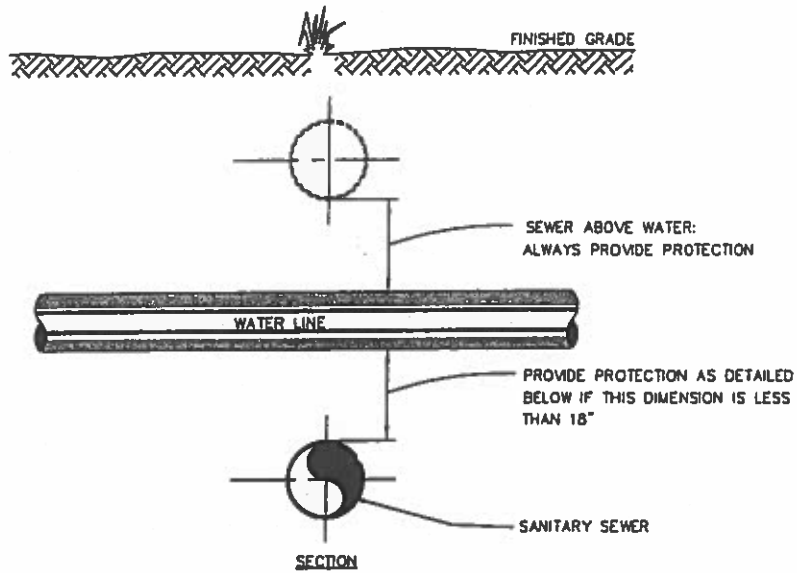

## Sewer Crossing Water Line Detail

THESE DETAILS ARE PROVIDED FOR STANDARDIZATION PURPOSES ONLY, THIS DETAIL REPRESENTS MINIMUM DESIGN STANDARDS WHICH MAY REQUIRE UPGRADING FOR SPECIFIC APPLICATIONS. REFER TO DISTRICT'S UTILITY CONSTRUCTION STANDARDS AND MINIMUM DESIGN CRITERIA FOR SPECIFIC MATERIAL AND INSTALLATION REQUIREMENTS.

Winter Park Ranch Water & Sanitation District  
Standard Details Dwg. A.8 JUNE 2008

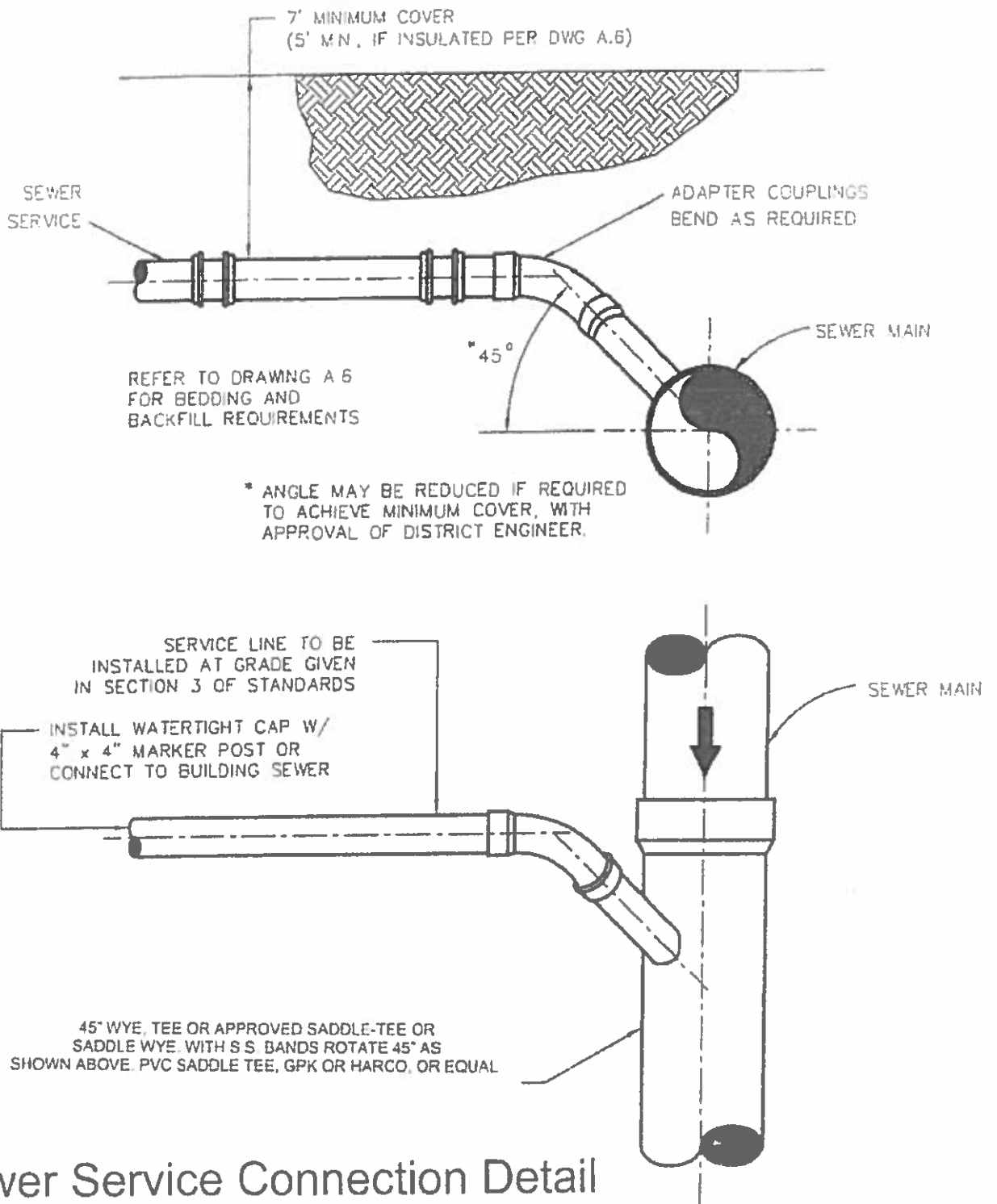

## Sewer Service Connection Detail

THESE DETAILS ARE PROVIDED FOR STANDARDIZATION PURPOSES ONLY. THIS DETAIL REPRESENTS MINIMUM DESIGN STANDARDS WHICH MAY REQUIRE UPGRADING FOR SPECIFIC APPLICATIONS. REFER TO DISTRICT'S UTILITY CONSTRUCTION STANDARDS AND MINIMUM DESIGN CRITERIA FOR SPECIFIC MATERIAL AND INSTALLATION REQUIREMENTS.

Winter Park Ranch Water & Sanitation District  
Standard Details Dwg. B.1 JUNE 2008

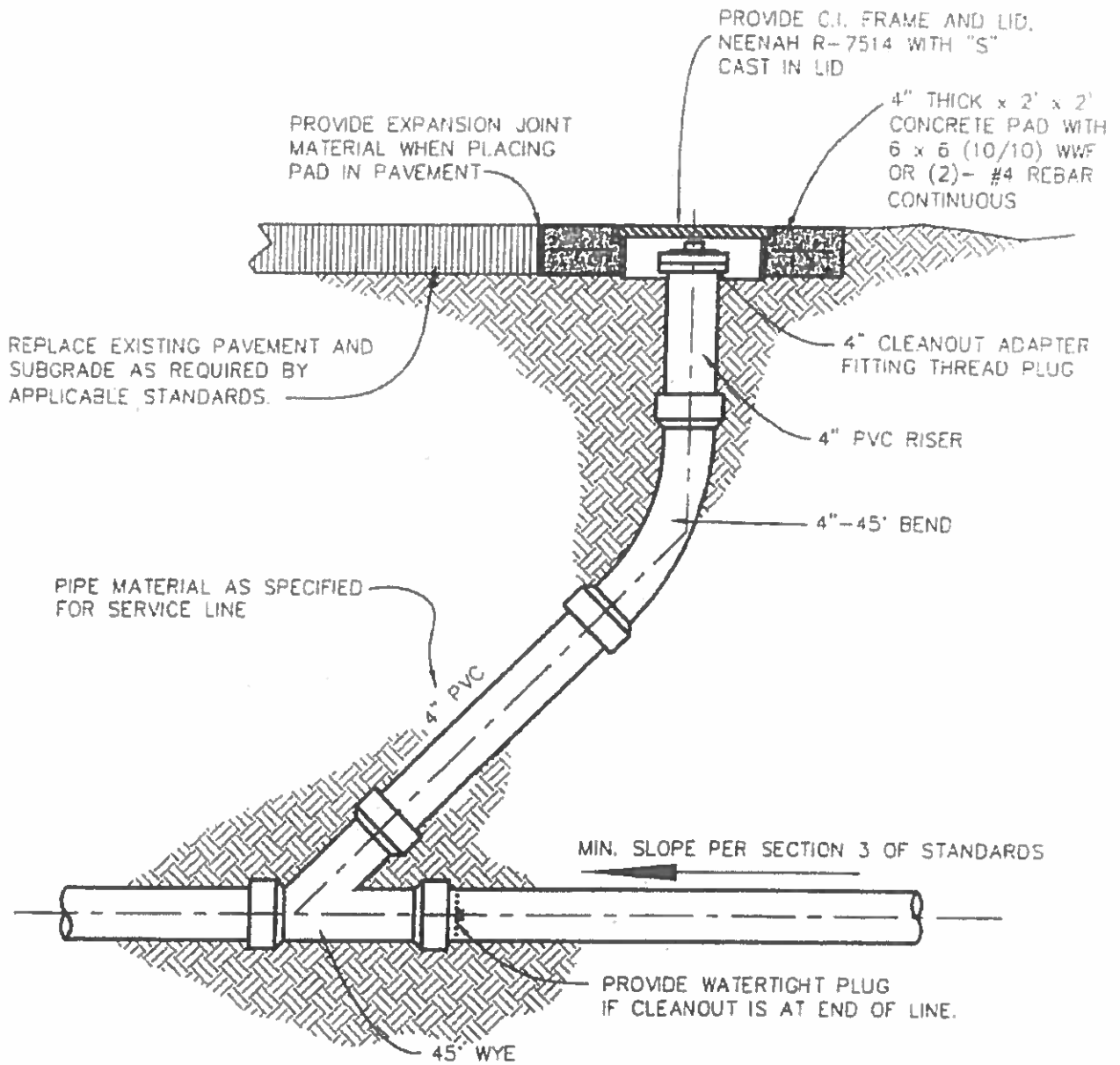

## Sewer Line Cleanout Detail

THESE DETAILS ARE PROVIDED FOR STANDARDIZATION PURPOSES ONLY. THIS DETAIL REPRESENTS MINIMUM DESIGN STANDARDS WHICH MAY REQUIRE UPGRADING FOR SPECIFIC APPLICATIONS. REFER TO DISTRICT'S UTILITY CONSTRUCTION STANDARDS AND MINIMUM DESIGN CRITERIA FOR SPECIFIC MATERIAL AND INSTALLATION REQUIREMENTS.

Winter Park Ranch Water & Sanitation District  
Standard Details Dwg. B.2 JUNE 2008

**RESOLUTION NO. 2009-7-21-1**

**A RESOLUTION ADOPTING WINTER PARK RANCH WATER AND SANITATION DISTRICT'S UPDATED CONSTRUCTION STANDARDS DATED APRIL, 2009**

WHEREAS, Winter Park Ranch Water and Sanitation District updated their construction standards in April 2009, as previously recommended by Gary Cooper, District Manager, and Kirk Klancke, District Manager;

NOW THEREFORE, be it resolved that Winter Park Ranch Water and Sanitation District adopts the updated construction standards.

THIS RESOLUTION WAS DULY APPROVED BY THE BOARD OF DIRECTORS OF THE WINTER PARK RANCH WATER AND SANITATION DISTRICT AT ITS REGULAR MEETING HELD ON JULY 21, 2009.

Winter Park Ranch Water & Sanitation District

  
By Chairman:

ATTEST:

  
Secretary